

charnwood

Woodworking machinery at its best!

10" x 7" PLANER THICKNESSER OWNERS MANUAL MODEL: W583



UK
CA
CE

Charnwood, Cedar Court, Walker Road, Hilltop Industrial Estate, Bardon,
Leicestershire, LE67 1TU

Tel. 01530 516 926
email: sales@charnwood.net

Fax. 01530 516 929
website: www.charnwood.net

GENERAL SAFETY RULES



WARNING: Do not attempt to operate the machine until you have read thoroughly and understood completely all instructions, rules, etc. contained in this manual. Failure to comply may result in accidents involving fire, electric shock, or serious personal injury. Keep this owner's manual and review frequently for continuous safe operation.

1. Know your machine. For your own safety, read the owner's manual carefully. Learn its application and limitations, as well as specific potential hazards pertinent to this machine.
2. Make sure all tools are properly earthed.
3. Keep guards in place and in working order. If a guard must be removed for maintenance or cleaning, make sure it is properly replaced before using the machine again.
4. Remove adjusting keys and spanners. Form a habit of checking to see that all keys and adjusting spanners are removed from the machine before switched it on.
5. Keep your work area clean. Cluttered areas and workbenches increase the chance of an accident.'
6. Do not use in dangerous environments. Do not use power tools in damp or wet locations, or expose them to rain. Keep work areas well illuminated.
7. Keep children away. All visitors should be kept a safe distance from the work area.
8. Make workshop childproof. Use padlocks, master switches and remove starter keys.
9. Do not force the machine. It will do the job better and be safer at the rate for which it is designed.
10. Use the right tools. Do not force the machine or attachments to do a job for which they are not designed. Contact the manufacturer or distributor if there is any question about the machine's suitability for a particular task.
11. Wear proper apparel. Avoid loose clothing, gloves, ties, rings, bracelets, and jewellery which could get caught in moving parts. Non-slip footwear is recommended. Wear protective hair covering to contain long hair.
12. Always use safety glasses. Normal spectacles only have impact resistant lenses. They are not safety glasses.
13. Do not over-reach. Keep proper footing and balance at all times.
14. Maintain the machine in good condition. Keep the machine clean for best and safest performance. Follow instructions for lubrication and changing accessories.
15. Disconnect the machine from power source before servicing and when changing the blade.
16. Never leave the machine running unattended. Turn the power off. Do not leave the machine until it comes to a complete stop.
17. Do not use any power tools while under the effects of drugs, alcohol or medication.
18. Always wear a face or dust mask if operation creates a lot of dust and/or chips. Always operate the tool in a well ventilated area and provide for proper dust removal. Use a suitable dust extractor.

ADDITIONAL RULES FOR PLANER/THICKNESSERS

1. This machine is designed for use with wood. Attempting to plane or thickness any other materials will result in damage to the machine, potential fire risk and/or health hazards.

2. The machine is designed for indoor use only.
3. Connection to a suitable dust extraction system is highly recommended. If you must use the machine on its own, you will need to stop it, unplug it from the mains and thoroughly clean it at regular intervals. Continuing to use the machine when it is clogged with shavings will result in damage to it, potential fire risk and/or health hazards.
4. The machine should only be used on the stand provided.
5. Always hold the work firmly on to the table, using push pads when necessary.
6. Never use the planer/thicknesser with the guard and/or dust hood removed.
7. If planing or thicknessing a long piece of timber, provide additional support at the same height as the table.
8. Switch the machine off and unplug it before removing any debris.
9. Be aware of the possibility of kickback.
10. Do not modify this machine in any way or use it or anything other than its designated purpose. Neither the manufacturer nor the suppliers will be liable for any damage or injury caused by incorrect assembly, operation or electrical connection of this machine.



Risk of Injury!
Never reach into
a running cutter block



**Wear Eye
Protection**



**Wear Ear
Protection**

Rating Description

Trade: Suitable for daily use by professional woodworkers.

Continuously rated, high power and a heavy duty construction. Typically used by several different operators in a small or medium sized business. Will be used up to the machines maximum limit with some long work periods. Expected maximum use of 1000 hours annually.

Please Note: Using a product in excess of its rating will void the manufacturer's free warranty.

Charnwood W583 Specification

Motor (induction)	1500w (2hp), 240v, 50hz
Planer width	250mm (10")
Maximum planing / Thicknessing cut	5mm / 2.5mm
Fence tilt	0 to 45°
Thicknessing capacity	5 to 195mm
Number of knives	3 x HSS
Dimensions of knives	251mm x 30mm x 3.2mm
Weight	150kg
Noise Level	87.3 dB(A)
Rating	Trade
Warranty	1 Year

Unpacking



This product is packed into 1 wooden crate.

To open the wooden crate, cut the strapping and lift the lid of the crate up from the pallet base.

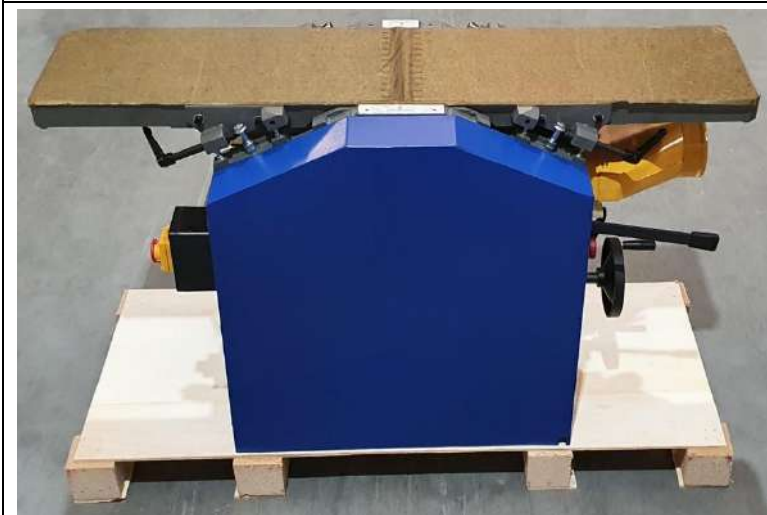

Remove the plastic cover and the items packed loosely around the sides.

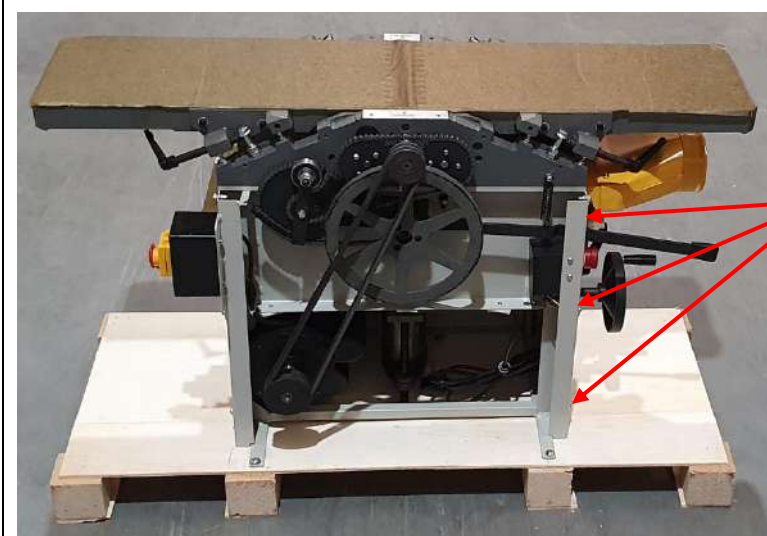

To remove the machine from the pallet base:

Using a cross head screwdriver, loosen but do not remove, 6 screws which secure the blue side cover.

Slide off the blue side cover.



The machine is fixed to the pallet base with two screws.

Use a 10mm spanner to undo the 2 securing screws.

Refit the blue side cover.

Identify The Loose Parts

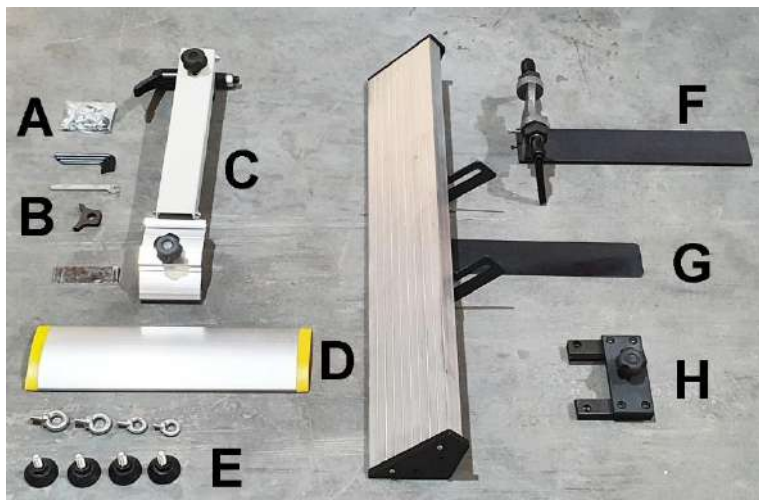

- A – Pack of Fixings
- B – Service Tools
- C – Bridge Guard Arm
- D – Cutter Guard
- E – Adjustable Feet
- F – Fence Guide Rail
- G – Side Fence
- H – Fence Guide Bracket

Assembly



Assemble the Base Stand:

Identify the 4 panels which make up the base stand.

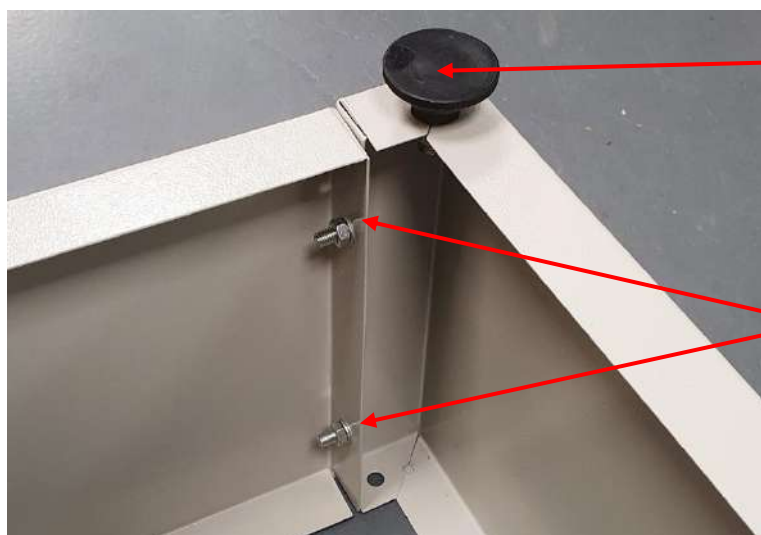

Fix 4 plastic feet into the 4 welded nuts on the underside of the base stand.

These can be adjusted later to level the machine.

Use 8 of the bolts, washers and nuts provided to assemble the 4 sides of the base stand.

Leave them finger tight for now.

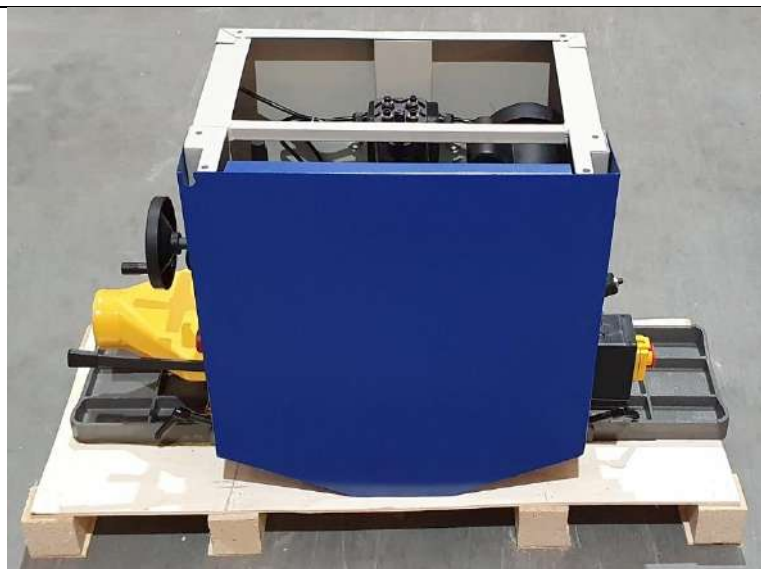

This part of the assembly requires 2 people: Flip the body of the machine upside down.

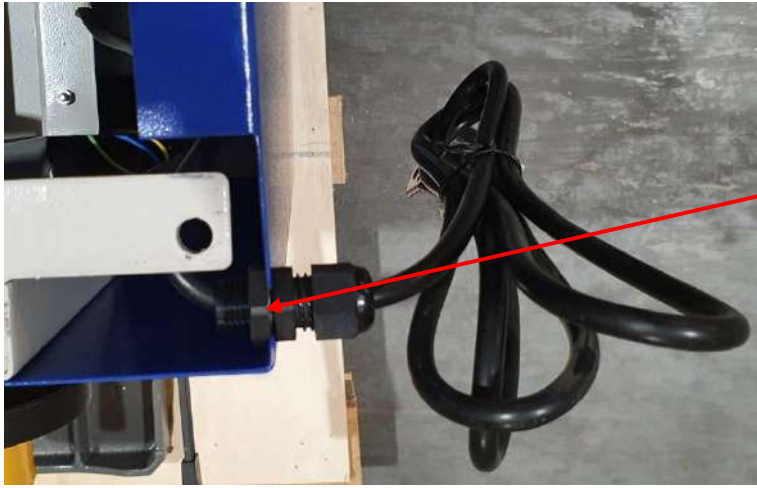

Feed the power cable through the cut out in the blue side cover.

Lock it in place using the nut on the cable grommet.

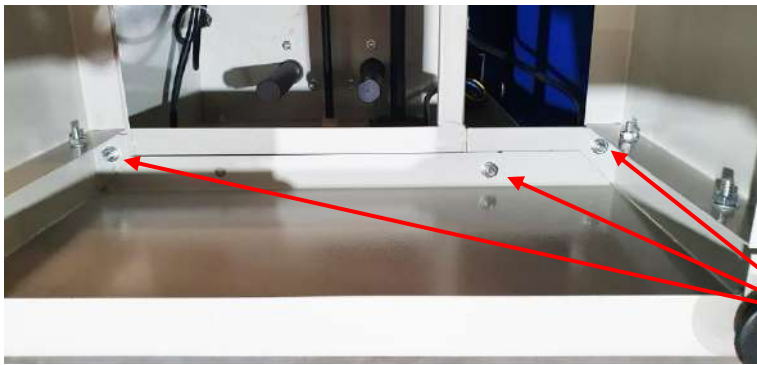

Place the assembled base stand onto the upturned machine.

Attach it using 6 of the bolts, washers and nuts provided.



Tighten all of the nuts on the base stand, using a pair of 10mm spanners.



This part of the assembly requires 2 people: Flip the machine back to right side up.

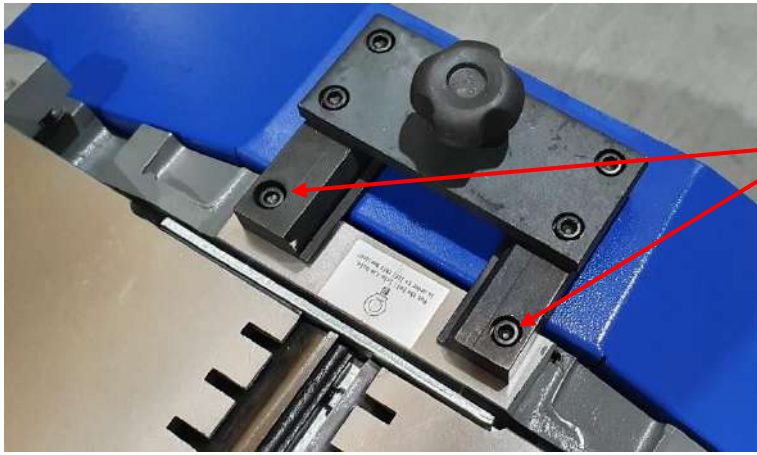

Assemble the fence:

Use a hex key to attach the Fence Guide Bracket to the body of the machine, with 2 bolts.

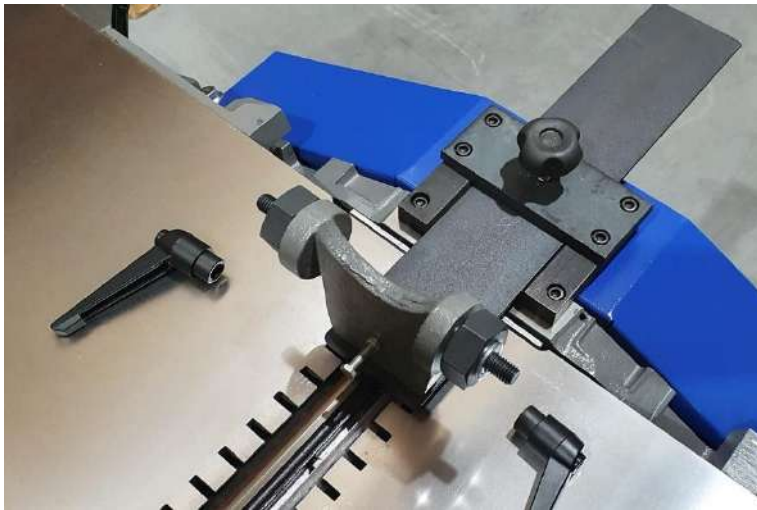

Slide the Fence Guide Rail into the Guide Bracket.

Remove the 2 ratchet handles.

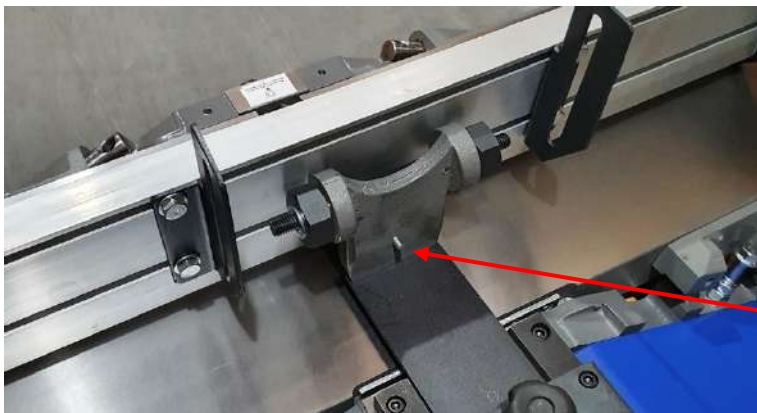

Insert the thin plate, which is already attached to the Side Fence, underneath the Fence Guide Rail, until the back of the fence touches the setting screw.

The setting screw is used to set the fence at 90 degrees to the table.



Slide the 2 slotted Angle Brackets over the two threaded studs.

Refit the ratchet handles and tighten them.

Use a 12mm spanner, to lock the 2 slotted Angle Brackets in place by tightening 4 bolts.

Check the angle between the fence and the table is 90 degrees.

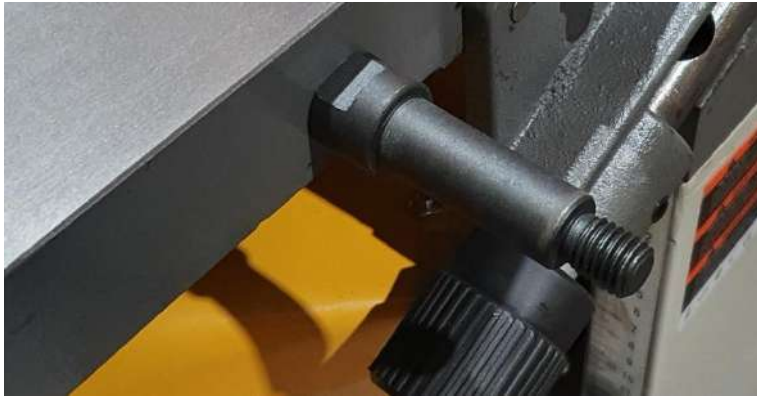

Assemble the Bridge Guard:

Locate the Bridge Guard Arm

Remove the nut from one end of the pivot shaft, remove the ratchet handle from the other end of the pivot shaft.

Take out the pivot shaft and screw it into the threaded hole in the side of the outfeed table.

Lock it in place with a 17mm spanner.

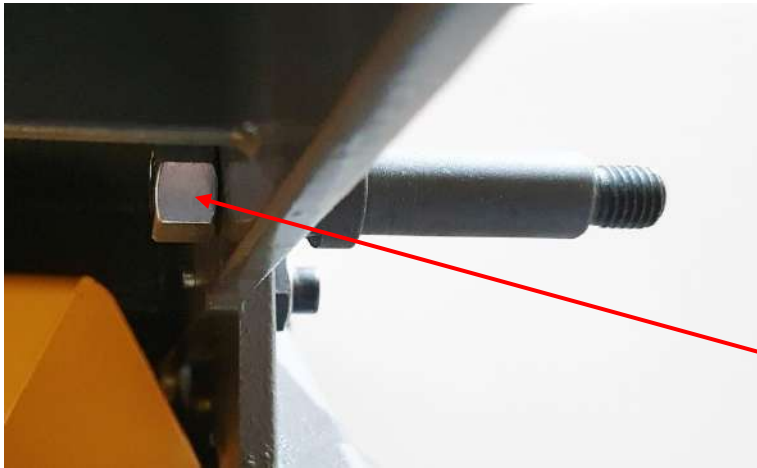

Refit the nut on the inside of the table. Tighten the nut with an 18mm spanner.

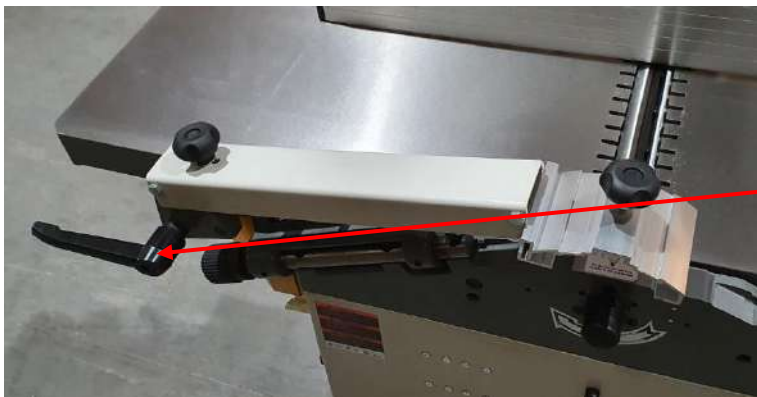

Slide the Bridge Guard Arm back onto the pivot shaft.

Refit the ratchet handle.



Fit the protection plate into the end of the cutter guard arm.

Slide the Cutter Guard into the Bridge Guard Arm.

Using the Planer Thicknesser

PLANING MODE

Side Fence

Outfeed Table

Bridge Guard Angle Lock

Bridge Guard Position Lock

Planing Depth Scale

Infeed Table

Planing Depth Adjuster

On / Off Switch

Adjustable Feet

Feed Direction

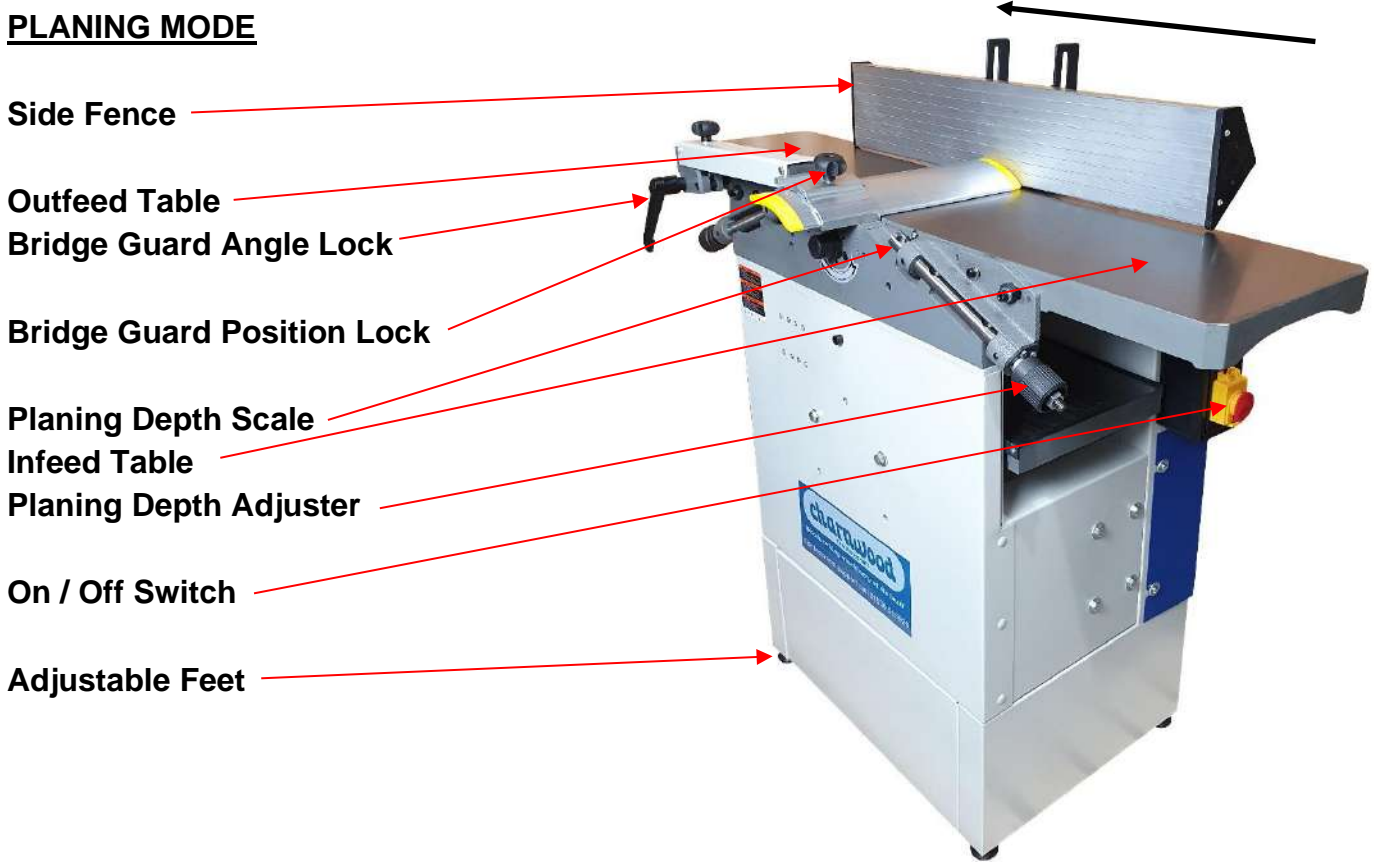

THICKNESSING MODE

Infeed Table Lock

Dust Hose Connection

Outfeed Table Lock

Cutter Guard

Side Fence Locking Knob

Thicknessing Scale

Engage/disengage Drive Rollers

Emergency Stop button

Thicknessing Table Height Adjuster

Thicknessing Table Lock

Feed Direction

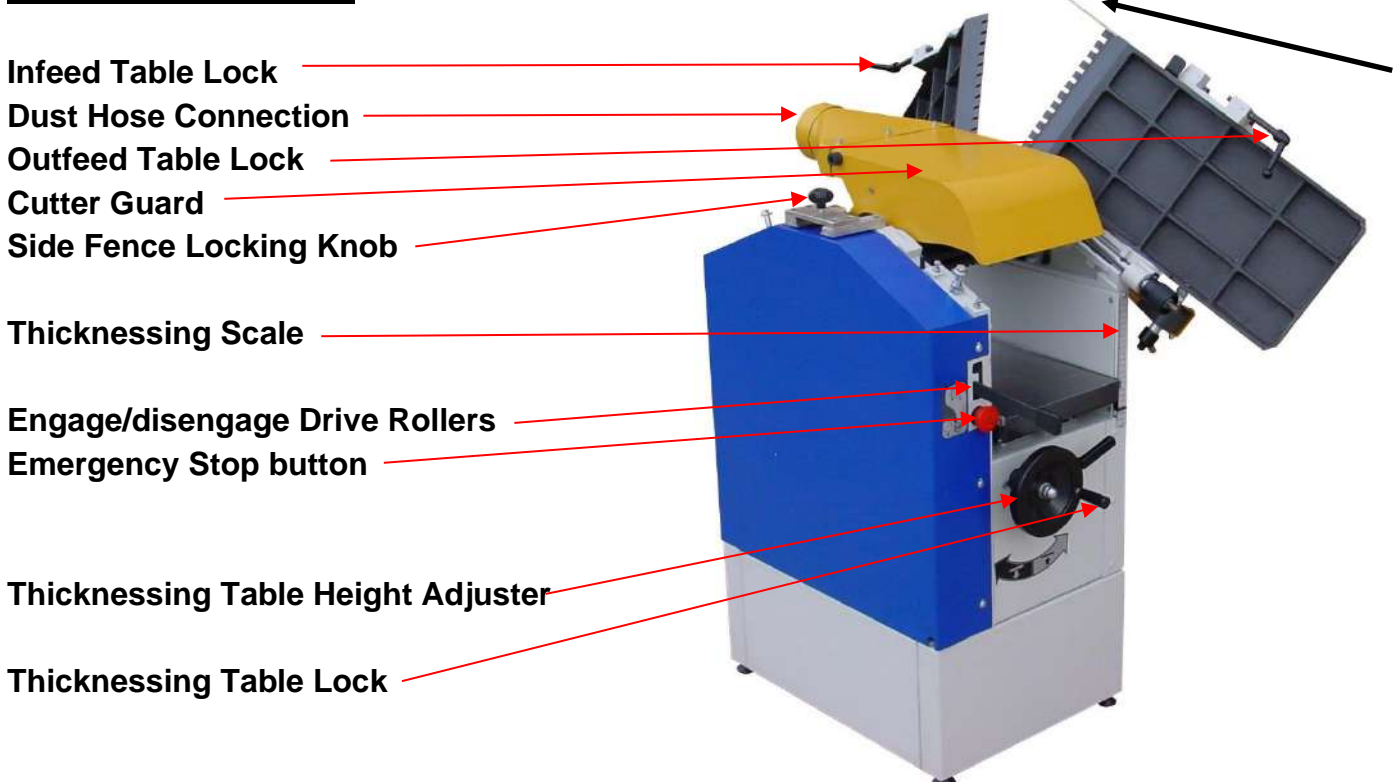

PLANING MODE

With the machine set up in planing mode:

Use the Bridge Guard Angle Lock to adjust the height of the Bridge Guard, so that the work piece can fit underneath.

Set the Planing Depth Adjuster to the desired setting, reading off the Planing Depth Scale. If in doubt set the depth to 0.5mm

Connect a dust extractor to the 100mm diameter outlet.

Start the machine, wait for it to get up to full speed.

Lay the work piece flat on the Infeed Table and push it over the cutter block. Use a push stick or push pad to ensure hands are kept well away from the cutters.

Pick up the work piece and return it to the starting position. Make as many passes as necessary to achieve a flat planed finish.

When planing deeper pieces, over 75mm, undo the locking knob and slide the Cutter Guard away from the Side Fence just enough to provide clearance for the workpiece.

SWITCHING MODES

To move from planing mode to thicknessing mode.

Undo the Bridge Guard Angle Lock and raise the arm to vertical, lock it there.

Undo the side Fence Locking Knob and remove the complete Side Fence.

Lower the Bridge guard.

Undo the Infeed Table Lock, swing the table up and over.

Undo the Outfeed Table Lock, swing the table up and over.

Take hose connector end of the Cutter Guard and swing it up and over the cutter block, until it clips into place.

Engage the drive rollers by moving the Lever into the upper position.

First Use Only: Carefully remove the protective film from the rubber coated drive roller.

THICKNESSING MODE

With the machine set up in Thicknessing mode.

Measure the thickness of the work piece. Turn the Height Adjuster handwheel to raise the thicknessing bed, read off the Thicknessing Scale to get to that depth, then raise the bed another 1 – 2.5mm. Use the Table Lock to secure it.

The feed direction is the opposite direction to planing mode.

Start the machine, wait for it to get up to full speed.

Lay the work piece flat on the end of the table. Slide it forward until you feel the drive rollers take it from you. Let go of the work piece and walk to the other end of the machine to support the work piece as it is fed out of the thicknesser.

A safety bar will prevent you from trying to make too big a cut. If the timber hits the safety bar, lower the table to take a smaller cut.

Make as many passes as necessary to get the desired finished dimension.

If making multiple components, consistency is best achieved by feeding them all through at one depth, before adjusting the table height and feeding them all through again.

General Method



When faced with a rough sawn piece of timber which requires planing on all 4 sides and taking down to a specific finished dimension, follow this guide:

- Set the machine up for planing.
- Identify the flattest of the two wider faces on the timber. (Face 1 on diagram)
- Pass that side over the planer as many times as necessary until a flat and smooth finish is achieved.
- Hold the planed side firmly against the guide fence (set at 90 degrees to the bed) and pass the narrow side (Face 2 on diagram) over the planer as many times as necessary until a flat and smooth finish is achieved.
- You should now have two planed sides at 90 degrees to each other.
- Set the machine up for thicknessing.
- Pass the timber through the thicknesser with the wider already planed side (Face 1 on diagram) facing down against the bed. Continue until the desired thickness for the timber is reached.
- Finally, pass the timber through the thicknesser with the planed narrow side (Face 2 on diagram) facing down against the bed. Continue until the desired thickness for the timber is reached.

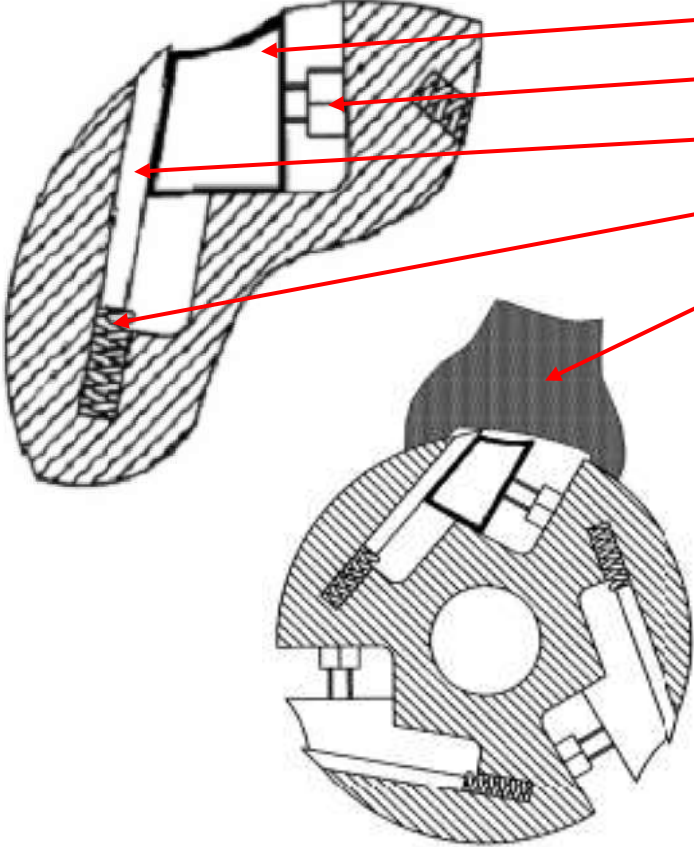

Knife Removal and Replacement

If you are using the optional knife setting jig, please read those instructions first.

<p>Cross Section Of Cutter Block</p> 	<p>Locking Bar Square Head Bolt Knife Spring Setting Tool</p> <p>Each knife is held in place by a locking bar.</p> <p>The locking bar is secured in place with 5 square head bolts, which are wound out to lock it.</p>
	<p>To remove the worn knives:</p> <p>Disconnect the machine from the power supply.</p> <p>Open both tables to get better access to the cutter block.</p>



Use the 7mm spanner provided to turn the bolts in a direction that winds them deeper into the locking bar. Continue until the knife can be removed.

Fit the new or reground knife into the cutter block. Note the direction of the beveled cutting edge and ensure the new knife is installed the correct way around.



The bottom edge of the knife sits on springs.

Press the knife setting tool against the cutting edge of the knife. Press it down until both radiused sides of the setting tool sit against the cutter block.

The knife will now project 0.75mm beyond the cutterblock. Wind the square head bolt out, to lock the knife in place.

Troubleshooting

Problem	Cause	Remedy
Machine does not start	Emergency stop activated	Release the emergency stop
	Blown Fuse	Replace Fuse
	Loose switch terminal	Inspect back of switch
	Faulty switch	Replace switch
Only starts when Green button is held down	Cutter Guard not in the correct position	Check the alignment of the micro switch
	Faulty switch	Replace switch
Machine hums but does not start	Start capacitor failed	Replace start capacitor
Cutter block runs at half speed, with lack of power	Run capacitor failed	Replace run capacitor
Motor running but cutter block is not rotating	Broken or stretched drive belt	Replace drive belt
Motor slows down during the cut	Depth of cut is too great	Take a smaller cut

	Dust & Chip collector hood is blocked	Clear the blockage and ensure the extractor is functioning correctly
	Planing knives are blunt	Replace or sharpen knives
Excess Vibration	Planing knives out of balance	Reset the height of the knives

Declaration of Conformity for CE Marking

Charnwood Declare that Woodworking Planer & Thicknesser, Model W583

Conforms with the following Directives: Machinery Directive 2006/42/EC
EMC Directive 2014/30/EU

Conforms with the following UK Regulations: Supply of Machinery (Safety) Regulations 2008
Electrical Equipment (Safety) Regulations 2016

And further conforms to the machinery example for which the EC type examination Certificate No. BM 50174252, AN 50174251 have been issued by TUV Rheinland LGA Products GmbH, Tillystrasse 2, 90431, Nurnberg.

I hereby declare that equipment named above has been tested and found to comply with the relevant sections of the above referenced specifications. The machinery complies with all essential requirements of the directives and regulations.

Signed: 

Dated: 01/09/2021

Location: Leicestershire



Richard Cook, Director



Please dispose of packaging for the product in a responsible manner. It is suitable for recycling. Help to protect the environment, take the packaging to the local amenity tip and place into the appropriate recycling bin.



Only for EU countries

Do not dispose of electric tools together with household waste material!

In observance of European Directive 2002/96/EC on waste electrical and electronic equipment (EEE) and its implementation in accordance with national law, electric tools that have reached the end of their life must be collected separately and returned to an environmentally compatible recycling facility.

Your local refuse amenity will have a separate collection area for EEE goods

Charnwood W583 Parts Diagrams

A: STAND ASSEMBLY

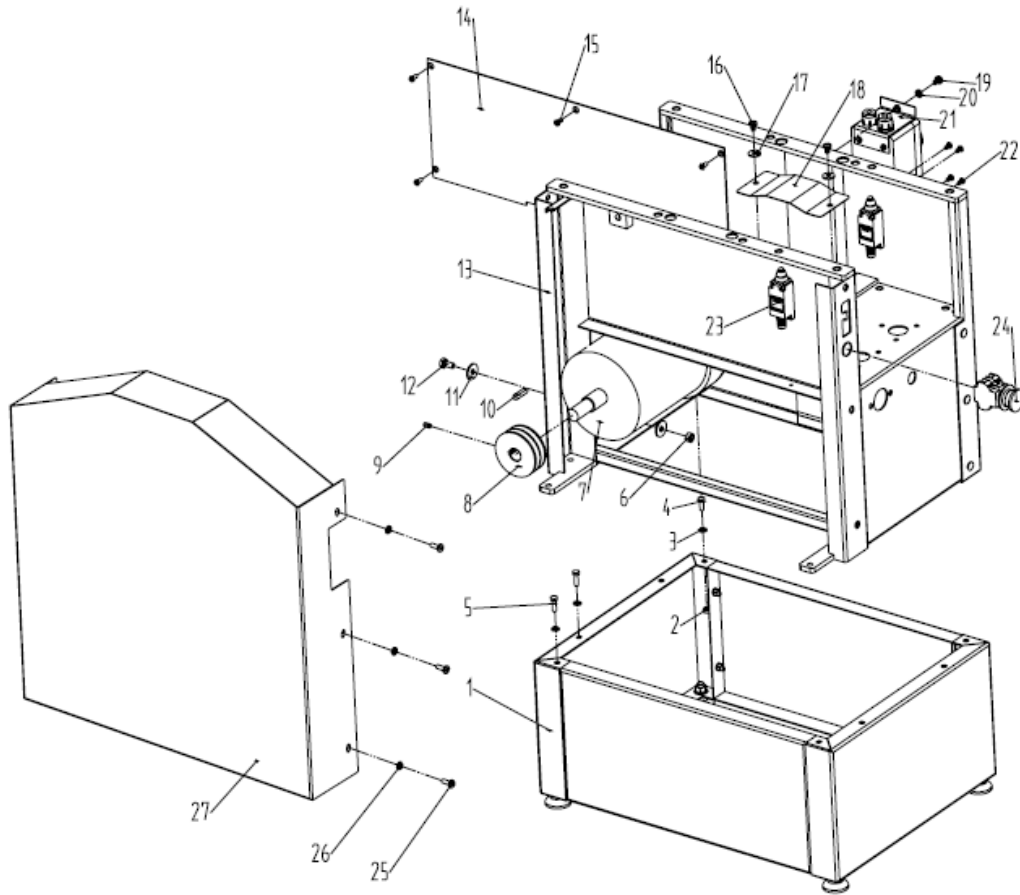

STAND ASSEMBLY

NO.	CODE	DESCRIPTION	QTY		NO.	CODE	DESCRIPTION	QTY
A01	M06-2	Lower stand	1		A02	GB6170-86	Hex nut M6	6
A03	GB97.1-85	Washerφ6	6		A04	GB5783-86	Hex bolt M6X16	2
A05	GB5783-86	Hex bolt M6X20	4		A06	GB6170-86	Hex nut M8	4
A07	M0607	Motor	1		A08	M0606	Motor pulley	1
A09	GB80-85	SetscrewM6X12	1		A10	GB1096-79	Key 6X25	1
A11	GB97.1-85	Washerφ8	8		A12	GB5783-86	Hex bolt M8X16	4
A13	M0603	Stand assembly	1		A14	M0609	Right plate	1
A15	GB819-85	Screw M5X10	5		A16	GB818-85	Screw M6X10	4
A17	GB97.1-85	Washerφ6	4		A18	M0602	Cover board	2
A19	GB818-85	Screw M6X10	2		A20	GB97.1-85	Washerφ6	2

A21	KJD12	Switch	1		A22	GB819-85	Screw M5X10	8
A23	WDKG	Inching switch	1		A24	JTKG	Emergency switch	1
A25	GB818-85	Screw M6X16	6		A26	GB97.1-85	Washer $\phi 6$	6
A27	M0601	Protective cover	1					

B: LOWER STAND ASSEMBLY

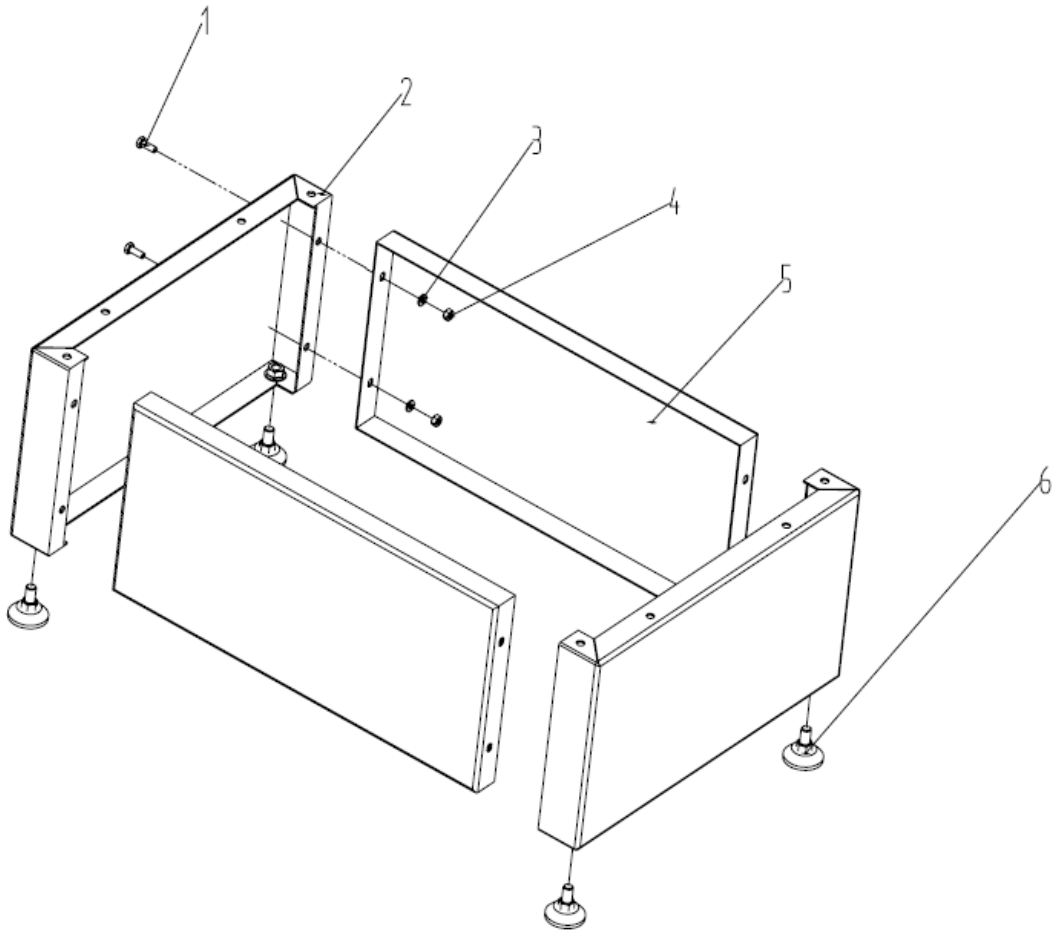

LOWER STAND ASSEMBLY

NO.	CODE	DESCRIPTION	QTY	NO.	CODE	DESCRIPTION	QTY
B01	GB5783-86	Hex bolt M6X16	8	B02	M0610	Lower leg	2
B03	GB97.1-85	Washer $\phi 6$	8	B04	GB6170-86	Hex nut M6	8
B05	M0611	Cover board	2	B06	M0613	Underprop	4

THICKNESSING TABLE ASSEMBLY

NO.	CODE	DESCRIPTION	QTY		NO.	CODE	DESCRIPTION	QTY
C01	M0716	Nylon bush	1		C02	GB818-85	Screw M4X6	2
C03	M12	Depth scale	1		C04	M0715-1	Handle	1
C05	M0715-2	Hand wheel	1		C06	GB6170-86	Hex nut M8	1
C07	M0710	Plate	1		C08	M0713	Shaft	1
C09	M0703	Adjusting bar	2		C10	M0711.1	Locking bar	1
C11	M0718	Locking block	1		C12	GB70-85	Socket cap screw M8X30	4
C13	GB93-87	Spring washer ϕ 8	4		C14	GB97.1-85	Washer ϕ 8	4
C15	GB70-85	Socket cap screw M6X30	1		C16	GB6170-86	Hex nut M6	1
C17	M0712	Plate	1		C18	GB70-85	Socket cap screw M6X12	4
C19	M0719	Bearing bush	1		C20	GB5783-86	Hex bolt M8X12	1
C21	GB97.1-85	Washer ϕ 8	1		C22	GB879-86	Spring pin 3X20	2
C23	M0714	Guide screw	1		C24	K1008	Cone gear	2
C25	M0720	Bush	1		C26	M0717	Gear box	1
C27	GZZC	Flat bearing	1		C28	ZSM10	Locknut M10	1
C29	GB923-88	Domed cap nut M12	1		C30	GB97.1-85	Washer ϕ 12	1
C31	GB1096-79	Key 5X15	1		C32	GB5783-86	Hex bolt M6X16	2
C33	GB97.1-85	Washer ϕ 6	2		C34	GB6170-86	Hex nut M6	2
C35	M0711	Locking handle	1		C36	GB879-86	Spring pin 3X20	1
C37	GB6170-86	Hex nut M6	6		C38	M0701	Washer	2
C39	M0702	Plate	2		C40	GB97.1-85	Washer ϕ 6	6
C41	GB5783-86	Hex bolt M6X16	6		C42	M0705	Thickness table	1
C43	M0706	Lifting pointer	1		C44	GB97.1-85	Washer ϕ 4	3
C45	GB818-85	Screw M4X6	3		C46	GB/T276-94	Bearing 6000	2
C47	YZYB	Grease cup M8X1	1		C48	M0709	Lifting tube bracket	1
C49	GB70-85	Socket cap screw M8X12	4		C50	M0708	Seal	1
C51	GB77-85	Set screw M6X10	4		C52	GB893.1-86	C ring ϕ 26	4
C53	M0721	Space bush	1		C54	GB819-85	Screw M4X12	12
C55	M0707	Limited bar	2		C56	GB70-85	Socket cap screw M8X12	6
C57	M0704	Lifting tube	1					

D: PLANER TABLE ASSEMBLY

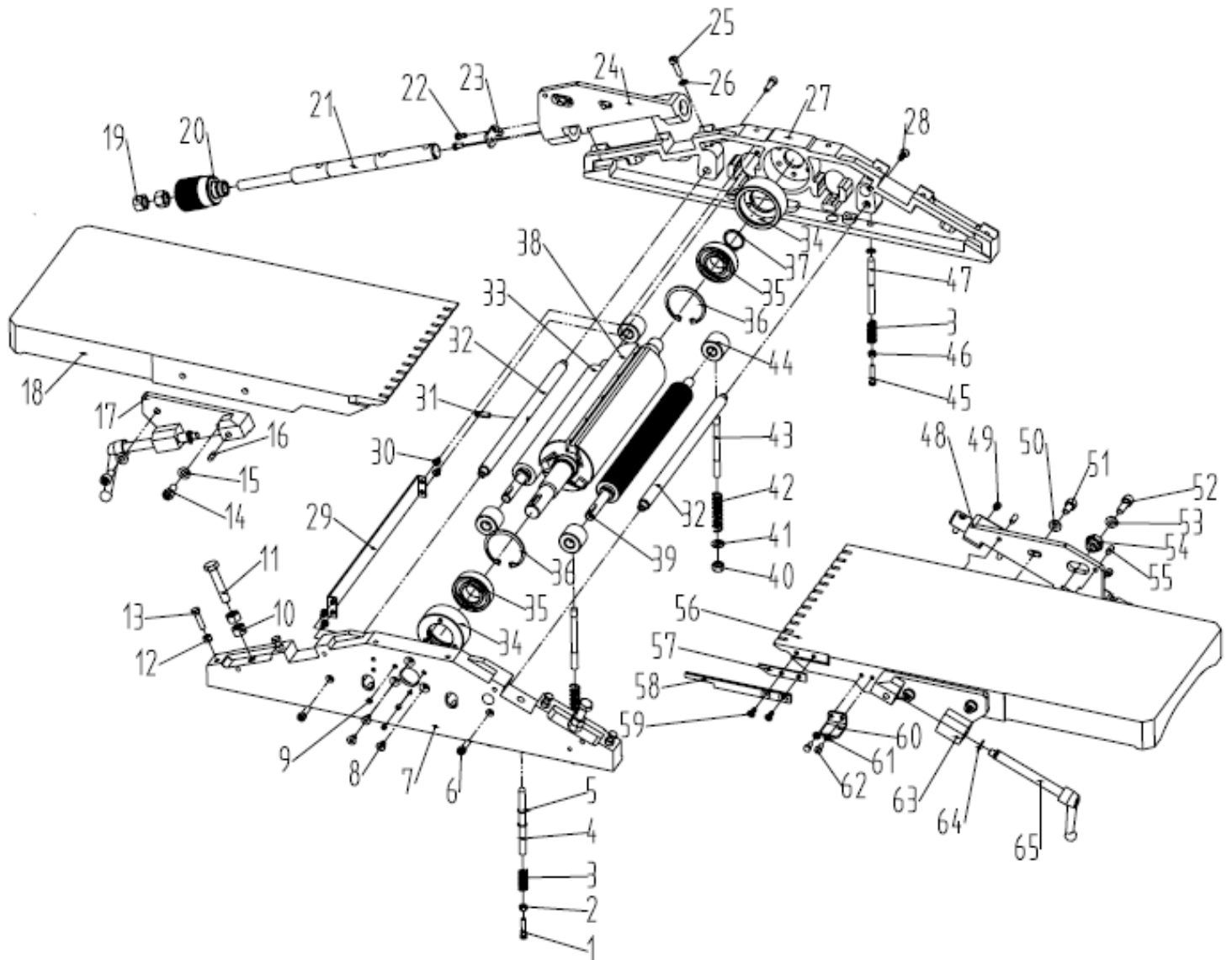

PLANER TABLE ASSEMBLY

NO.	CODE	DESCRIPTION	QTY	NO.	CODE	DESCRIPTION	QTY
D01	GB5783-86	Hex bolt M5X25	1	D02	GB6170-86	Hex nut M5	1
D03	M081213	Spring	2	D04	M081205-1	Limited pole	1
D05	GB896-86	"E" ring ϕ 6	3	D06	GB70-85	Socket cap screw M6X20	3
D07	M081202	Left bracket	1	D08	NCM	Socket countersunk screw M6X10	6
D09	GB77-85	Set screw M6X5	6	D10	GB6170-86	Hex nut M10	4

D11	GB5783-86	Hex bolt M10X50	2		D12	GB6170-86	Hex nut M6	4
D13	GB5783-86	Hex bolt M6X25	4		D14	GB70-85	Socket cap screw M8X16	4
D15	GB97.1-85	Washer ϕ 8	4		D16	GB119-86	Pin 6X16	2
D17	M1102	Locking block	1		D18	M1101	Outfeed table	1
D19	GB6170-86	Hex nut M12	4		D20	M1011	Adjusting wheel	1
D21	M1006	Adjusting axle	2		D22	GB5783-86	Hex bolt M5X10	4
D23	M1007	Metal plate	2		D24	M1103	Adjusting wing	1
D25	GB70-85	Socket cap screw M6X20	6		D26	GB93-87	Spring washer ϕ 6	6
D27	M081201	Right bracket	1		D28	NCM	Socket countersunk screw M6X16	1
D29	M081208	Protective plate	1		D30	GB818-85	Screw M5X8	4
D31	GB879-86	Spring pin 6X20	1		D32	M0904	Support axle	2
D33	M081209	Driven roller	1		D34	M081204	Bearing bush	2
D35	GB/T276-94	Bearing 6205	2		D36	GB893.1-86	“C” ring ϕ 52	2
D37	GB894.1-86	“C” ring ϕ 25	1		D38	M081207	Cutter block	1
D39	M081206	Driving roller	1		D40	GB6170-86	Hex nut M8	4
D41	GB/T848-85	Small washer ϕ 8	4		D42	M081211	Spring	4
D43	M081212	double-edged bolt	4		D44	M081203	Bush	4
D45	GB5783-86	Hex bolt M5X25	1		D46	GB6170-86	Hex nut M5	1
D47	M081205-2	Limited bar	1		D48	M1005	Adjusting wing	1
D49	GB77-85	Set screw M8X8	4		D50	GB97.1-85	Washer ϕ 8	2
D51	GB70-85	Socket cap screw M8X16	2		D52	GB70-85	Socket cap screw M8X25	2
D53	GB97.1-85	Washer ϕ 8	2		D54	M1004	Eccentric bush	2
D55	GB119-86	Pin 6X16	4		D56	M1001	Infeed table	1
D57	M1010	Space plate	1		D58	M1009	Locking plate	1
D59	GB819-85	Screw M5X12	2		D60	M1013	Press plate	1
D61	GB97.1-85	Washer ϕ 5	2		D62	GB5783-86	Hex bolt M5X10	2
D63	M1002	Locking block	1		D64	GB894.1-86	“C” ring ϕ 12	2
D65	M1003	Locking handle	2					

E: CUTTER BLOCK ASSEMBLY

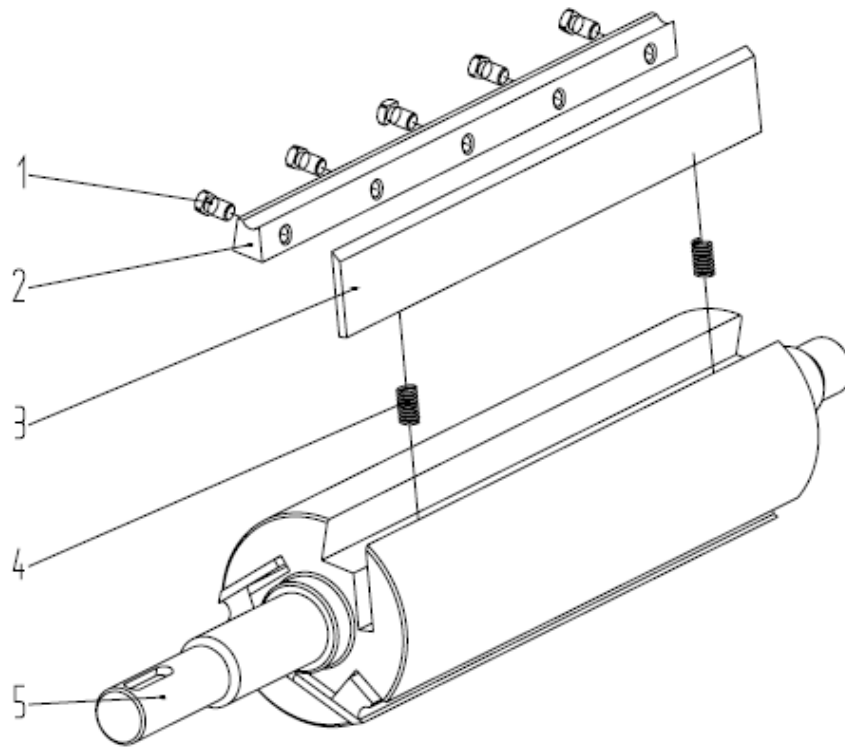

CUTTER BLOCK ASSEMBLY

NO.	CODE	DESCRIPTION	QTY	NO.	CODE	DESCRIPTION	QTY
E01	M081207.3	Square toes bolt	15	E02	M081207.2	Blade locking block	3
E03	M081207.5	Blade	3	E04	M081207.4	Spring	6
E05	M081207.1	Cutter block	1				

F: CLUTCH ASSEMBLY

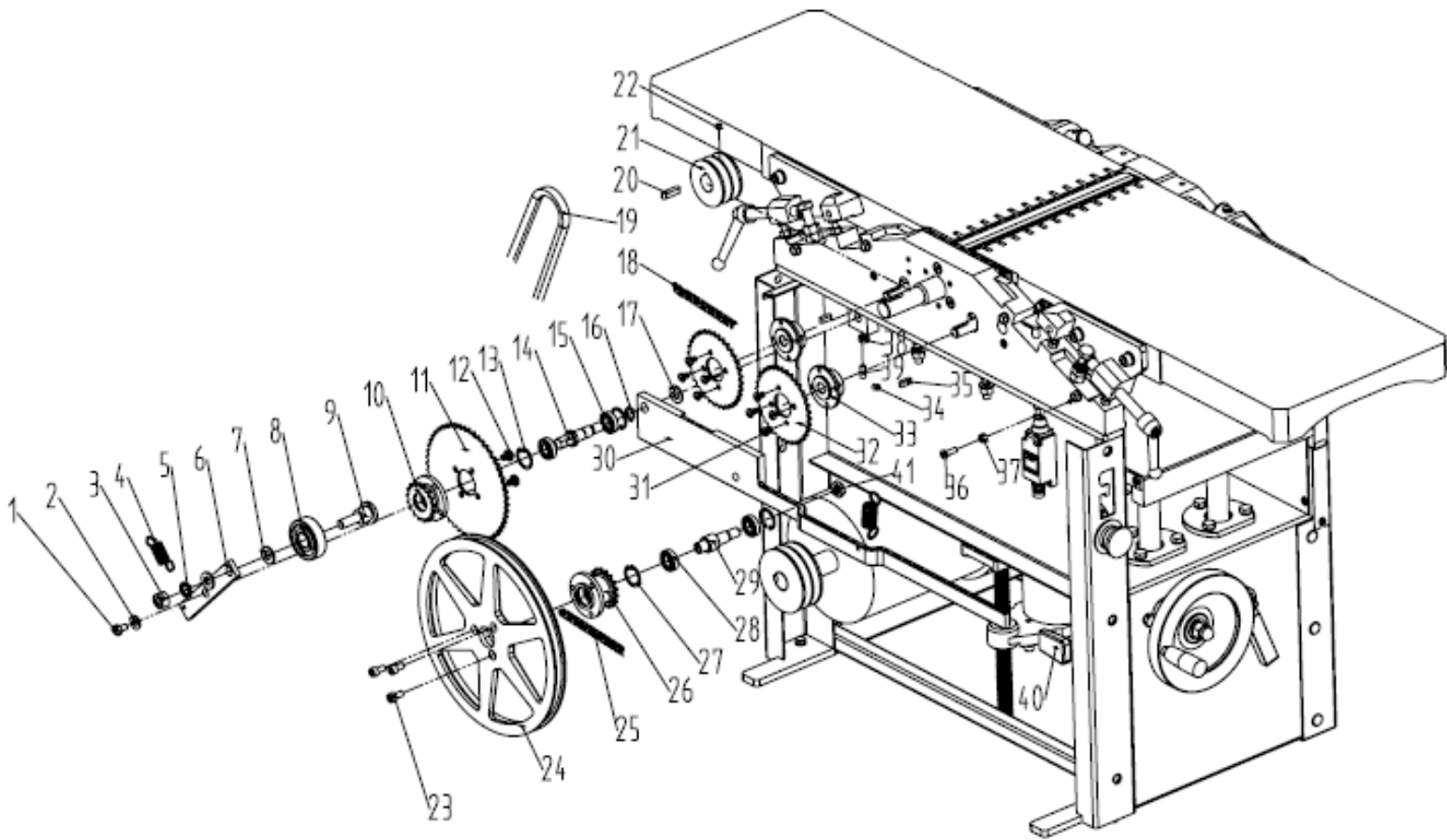

CLUTCH ASSEMBLY

NO.	CODE	DESCRIPTION	QTY	NO.	CODE	DESCRIPTION	QTY
F01	GB5783-86	Hex bolt M6X10	1	F02	GB97.1-85	Washer ϕ 6	1
F03	GB6170-86	Hex nut M10	1	F04	M082218	Pull spring	2
F05	GB93-87	Spring washer ϕ 10	1	F06	M082202	plate	1
F07	GB97.1-85	washer ϕ 10	2	F08	GB/T276-94	Bearing 80303	1
F09	M082217	Pin axle	1	F10	M082205	Sprocket	1
F11	M082201	Sprocket	1	F12	GB818-85	Screw M6X8	4
F13	GB893.1-86	"C" ring ϕ 24	2	F14	M082215	Long pin	1
F15	GB/T276-94	Bearing 61901	2	F16	GB894.1-86	"C" ring ϕ 12	1
F17	GB97.1-85	Washer ϕ 10	1	F18		Chain	1
F19	SJD	V-belt	2	F20	GB1096-79	Pin 6X25	1
F21	M082208	Cutter block pulley	1	F22	GB77-85	Screw M6X5	1
F23	GB70-85	Socket cap screw M6X14	3	F24	M082213	Wheel	1
F25		Chain	1	F26	M082207	Sprocket	1
F27	GB893.1-86	"C" ring ϕ 24	2	F28	GB/T276-94	Bearing 61901	2

F29	M082216	Short pin	1		F30	M082206	Control handle	1
F31	GB818-85	Screw M5X8	8		F32	M082210	Sprocket	2
F33	M082210.1	Sprocket plate	2		F34	GB77-85	Set screw M6X8	2
F35	GB1096-79	Key 5X16	2		F36	GB818-85	Screw M5X16	1
F37	GB6170-86	Hex nut M5	1		F38	GB6170-86	Hex nut M6	1
F39	GB80-85	Set screw M6X20	1		F40	M082219	Handle	1
F41	GB6173-86	Hex thin nut M10	1					

G: DUST EXTRACTION ASSEMBLY

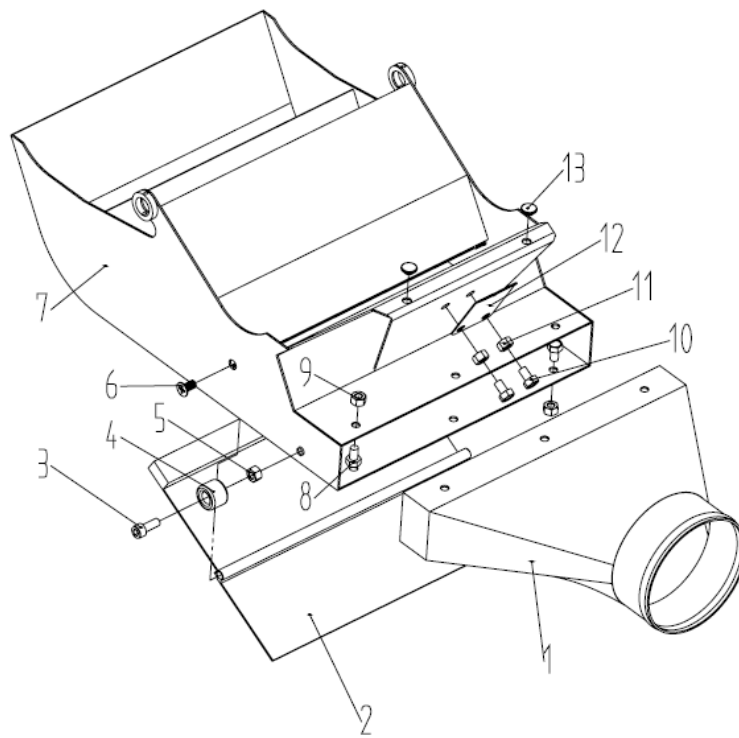

DUST EXTRACTION ASSEMBLY

NO.	CODE	DESCRIPTION	QTY		NO.	CODE	DESCRIPTION	QTY
G01	M0901.1	Dust extraction hood	1		G02	M0901.7	Turning plate	1
G03	GB70-85	Socket cap screw M6X16	1		G04	M0906	Rubber tray	1
G05	GB6170-86	Hex nut M6	1		G06	GB819-85	Screw M6X12	2
G07	M0901	Dust chute	1		G08	GB5783-86	Hex bolt M6X10	6
G09	GB6170-86	Hex nut M6	6		G10	GB5783-86	Hex bolt M6X10	2
G11	GB6170-86	Hex nut M6	2		G12	M0907	Locking plate	1
G13	M0905	Damping tray	2					

J: FENCE ASSEMBLY

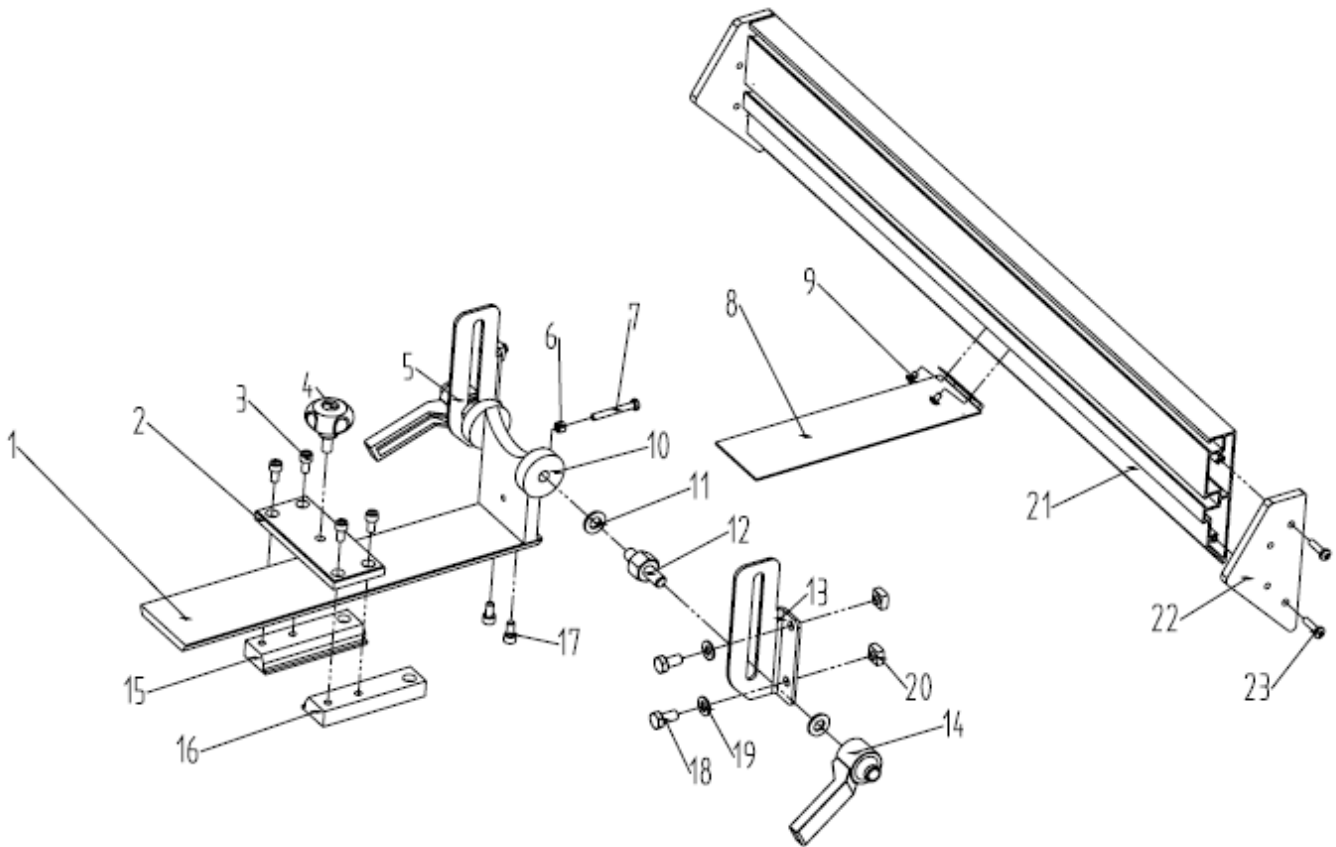

FENCE ASSEMBLY

NO.	CODE	DESCRIPTION	QTY	NO.	CODE	DESCRIPTION	QTY
J01	M1409	Guide rail	1	J02	M1411	Connecting plate	1
J03	GB70-85	Socket cap screw M6X12	4	J04	M1414	Locking handle	1
J05	M1401	Left metal plate	1	J06	GB6170-86	Hex nut M5	1
J07	GB5783-86	Hex bolt M5X40	1	J08	M1407	Sliding plate	1
J09	GB867-86	Rivet 4X6	2	J10	M1404	Bracket	1
J11	GB97.1-85	Washer ϕ 10	4	J12	M1403	double-edged bolt	2
J13	M1405	Right sliding block	1	J14	M1413	Locking handle	2
J15	M1408	Left metal plate	1	J16	M1410	Right metal plate	1
J17	GB70-85	Socket cap screw M6X12	2	J18	GB5783-86	Hex bolt M8X16	4
J19	GB97.1-85	Washer ϕ 8	4	J20	M1412	Square toes nut	4
J21	M1402	Fence	1	J22	M1406	Angle plate	2
J23	ZGM	Screw M5X20	4				

H: BRIDGE GUARD ASSEMBLY

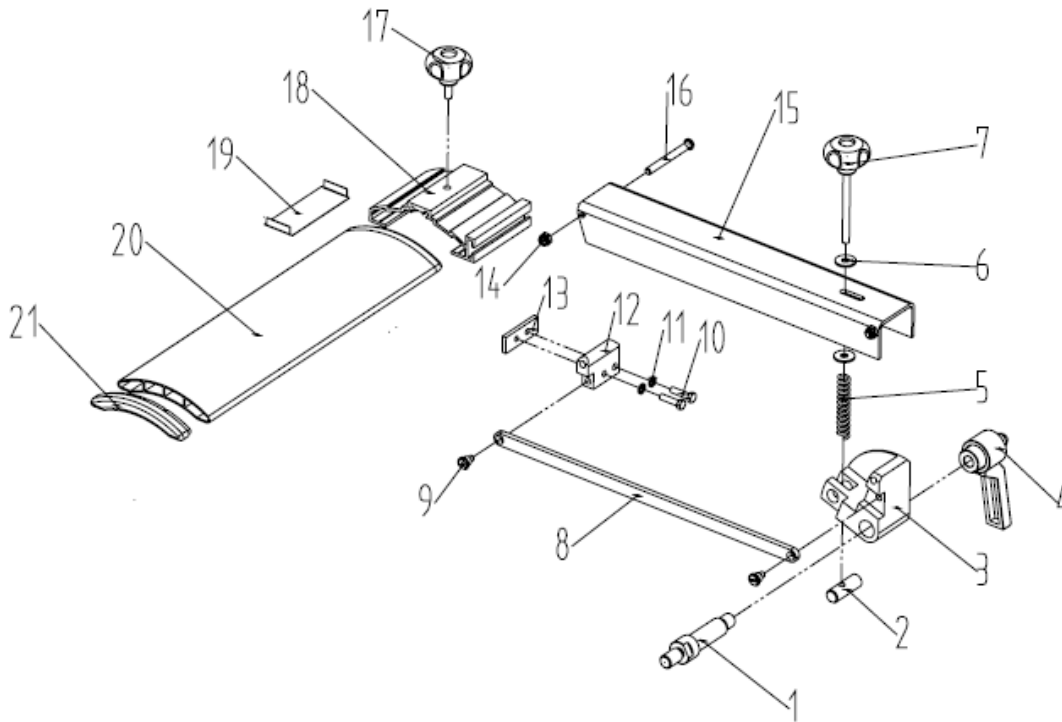

BRIDGE GUARD ASSEMBLY

NO.	CODE	DESCRIPTION	QTY	NO.	CODE	DESCRIPTION	QTY
H01	M1012.1	Locking pole	1	H02	M1602	Rotor	1
H03	M1610	Sector plate	1	H04	M1012	Locking handle	1
H05	M1603	Spring	1	H06	GB96-85	Large washer ϕ 6	2
H07	M1605	Adjusting handle	1	H08	M1609	Connecting pole	2
H09	M1611	Pin bolt	2	H10	GB5783-86	Hex bolt M5X20	2
H11	GB93-87	Spring washer ϕ 5	2	H12	M1612	Rock block	1
H13	M1606	Fixing plate	1	H14	ZSM	Locking nut M6	2
H15	M1601	U-shaped arm	1	H16	M1613	Long pin	1
H17	M1614	Locking handle	1	H18	M1608	Crust	1
H19	M1604	Saucer	1	H20	M1607	Protective plate	1
H21	M1615	Plastic insert	2				

I: FINAL ASSEMBLY

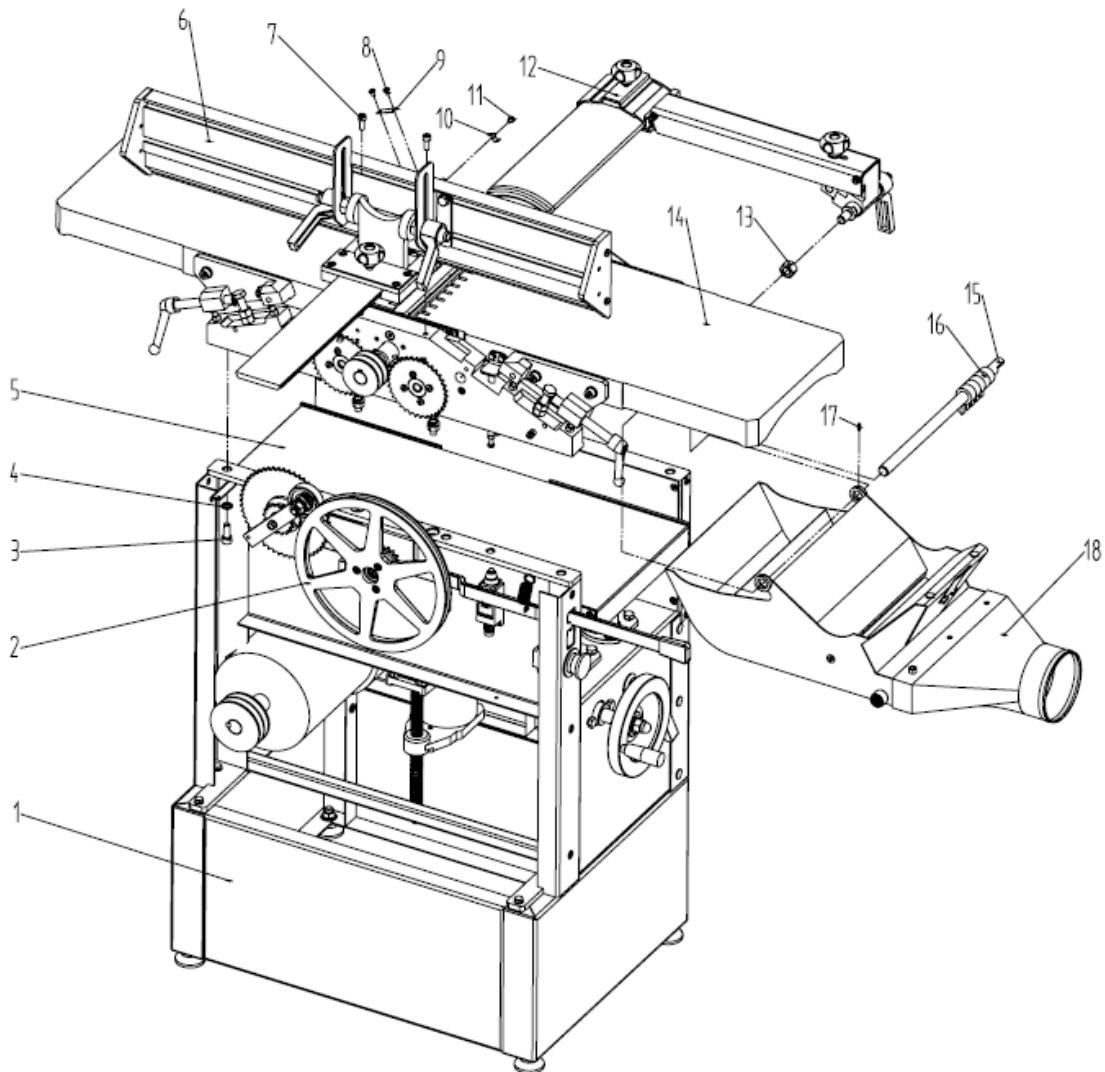

FINAL ASSEMBLY

NO.	CODE	DESCRIPTION	QTY	NO.	CODE	DESCRIPTION	QTY
I01	M06	Stand assembly	1	I02	M0822	Thicknesser clutch assembly	1
I03	GB70-85	Socket cap screw M8X20	8	I04	GB93-87	Spring washer ϕ 8	8
I05	M07	Thicknessing table assembly	1	I06	M14	Fence assembly	1
I07	GB70-85	Socket cap screw M6X16	2	I08	GB818-85	Screw M4X6	2
I09	M18	Infeed scale	1	I10	M20	Infeed pointer	1
I11	GB818-85	Screw M4X6	2	I12	M16	Protective cover assembly	1
I13	GB6170-86	Hex nut M12	1	I14	M10	Planer table assembly	1
15	M0902	Rotor	1	16	M0903	Kick block	20
17	GB879-86	Spring pin 3X10	1	18	M09	Extraction dust assembly	1



Woodworking machinery at its best!

Last Updated February 2022

**Charnwood, Cedar Court, Walker Road, Hilltop Industrial
Estate, Bardon, Leicestershire, LE67 1TU**

**Tel. 01530 516 926
email: sales@charnwood.net**

**Fax. 01530 516 929
website: www.charnwood.net**