

Instruction Manual

_____ Oscillating spindle sanding machine

_____ OSS 100



OSS 100

OSS 100

Imprint

Product identification

Oscillating spindle sanding machine	Item number
OSS 100	5903500

Manufacturer

Stürmer Maschinen GmbH
 Dr.-Robert-Pfleger-Str. 26
 D-96103 Hallstadt

Fax: 0049 (0) 951 96555-55
 E-Mail: info@holzstar.de
 Internet: www.holzstar.de

Indications regarding the operating instructions

Original instructions

Edition: 28.07.2020
 Version: 1.04
 Language: English

Author: MS/ES/FL

Indications regarding the copyright

Copyright © 2020 Stürmer Maschinen GmbH, Hallstadt, Germany.

The contents of these operating instructions is the sole property of the company Stürmer Maschinen GmbH. Passing on as well as copying of this document, the use and distribution of its content are prohibited if not explicitly permitted. Contraventions are liable to compensation.

Subject to technical modifications and error.

Contents

1 Introduction	3
1.1 Copyright	3
1.2 Customer service	3
1.3 Limitation of liability	3
2 Safety	3
2.1 Symbol explanation	3
2.2 Obligations of the operating company	4
2.3 Qualification of personnel	5
2.4 Personal protective equipment	5
2.5 Safety signs on the Machine	6
2.6 Regulations for safety and accident prevention ..	6
3 Intended Use	6
4 Technical Data	7
4.1 Table	7
4.2 Type plate	7
5 Transport, packaging, storage	7
5.1 Delivery and transport	7
5.2 Packaging	8
5.3 Storage	8
6 Scope of delivery and Accessories	8
6.1 Scope of delivery	8
6.2 Accessories	8
7 Description	8
8 Assembly and Connection	9
8.1 Fixing	9
8.2 Electrical connection	9
8.3 Connection for extraction system	9
8.4 Mounting the tool	9
9 Working with the machine	11
9.1 General	11
9.2 Workflow	11
9.3 Notes for the grinding process	11
10 Care, maintenance and repair	12
10.1 Cleaning	12
10.2 Maintenance	12
11 Troubleshooting	13
12 Disposal instructions / Recycling options	13
12.1 Decommission	13
12.2 Disposal of new equipment packaging	13
12.3 Disposal of electrical appliances	14
12.4 Disposal of lubricants	14
12.5 Disposal via municipal collection points	14
13 Spare parts	14
13.1 Ordering spare parts	14
13.2 Spare Parts Drawing	15
14 EC Declaration of Conformity	16
15 Notes	17

1 Introduction

You have made a good choice by purchasing the Oscillating spindle sanding machine made by HOLZSTAR.

Thoroughly read the operating instructions before commissioning the machine.

It informs you about the proper commissioning, the intended use as well as the safe and efficient operation and maintenance of the Oscillating spindle sanding machine. The operating instructions are part of the Oscillating spindle sanding machine. Always keep it at the place of use of the Oscillating spindle sanding machine. Furthermore, the local accident prevention regulations and the general safety notes are applicable for the field of application of the Oscillating spindle sanding machine. The illustrations in these operating instructions serve the general comprehension and may deviate from the actual type.

1.1 Copyright

The contents of these instructions are copyright. Their application is admissible in the frame of the device. An application beyond the described application is not allowed without written approval of the manufacturer. For the protection of our products, we shall register trademark, patent and design rights, as this is possible in individual cases. We strongly oppose any infringement of our intellectual property.

1.2 Customer service

Please contact your dealer if you have questions on the machine or if you need technical advice. They will help you with specialist information and expert advice.

Stürmer Maschinen GmbH
Dr.-Robert-Pfleger-Str. 26
D-96103 Hallstadt

Repair service:

Fax: 0049 (0) 951 96 555 - 55
E-Mail: service@stuermer-maschinen.de

Spare part orders:

Fax: 0049 (0) 951 96555-119
E-Mail: ersatzteile@stuermer-maschinen.de

We are always interested in valuable experience and knowledge gained from using the application, which then could be shared and be valuable to develop our products even further.

1.3 Limitation of liability

All information and notes in these operating instructions were summarised taking the applicable standards and rules, the state-of-the-art and our long-term knowledge and experiences into consideration.

In the following cases the manufacturer is not liable for damages:

- Non-observance of the operating instructions,
- Inappropriate use
- Use of untrained staff,
- Unauthorised modifications
- Technical changes,
- Use of not allowed spare parts.

The actual scope of delivery may deviate from the explanations and presentations described here in case of special models, when using additional ordering options or due to latest technical modifications.

The obligations agreed in the delivery contract, the general terms and conditions as well as the delivery conditions of the manufacturer and the legal regulations at the time of the conclusion of the contract are applicable.

2 Safety

This paragraph will give you an overview of all important safety packages for the protection of the people using it well as for a safe and undisturbed operation. Other task-based safety notes are included in the individual chapters.

2.1 Symbol explanation

Safety instructions

The safety notes in these operating instructions are highlighted by symbols. The safety notes are introduced by signal words which express the concern of the risk.



DANGER!

This combination of symbol and signal words indicates an imminently dangerous situation which may lead to death or severe injuries if they are not avoided.



WARNING!

This combination of symbol and signal word indicates a potentially dangerous situation that can lead to death or serious injury if not avoided.



CAUTION!

This combination of symbol and signal word indicates a potentially dangerous situation that can result in minor injury if it is not avoided.



ATTENTION!

This combination of symbol and signal words indicates a possibly dangerous situation which may lead to property and environmental damages if they are not avoided.



NOTE!

This combination of symbol and signal words indicates a possibly dangerous situation which may lead to property and environmental damages if they are not avoided.

Tips and recommendations



Tips and recommendations

This symbol highlights useful tips and recommendations as well as information for an efficient and trouble-free operation.

It is necessary to observe the safety notes quoted in these operating instructions in order to reduce the risks for personal injuries and damages to property.

2.2 Obligations of the operating company

The operating company is the person who operates the machine for business or commercial reasons by herself, or leaves it to a third party for use or application, and who bears the legal product responsibility for the protection of the user, the staff or for third parties.

Obligations of the operating company:

If the machine is used for commercial purposes, the operating company must comply with the legal working safety regulations. Therefore, the safety notes in this operating manual, as well as the safety, accident prevention and environment protection regulations applying for the area of application of the machine must be met. The following applies in particular:

- The operating company must be informed about the applying industrial safety regulations and further analyse hazards resulting from the special working conditions at the place of use machine. She must implement these in form of operating manuals for the operation machine.
- During the entire lifetime of machine, the operating company must verify whether the operating manuals prepared by her correspond to the current status of the regulations, and must adapt these if necessary.
- The operating company must unambiguously regulate and determine the responsibilities for installation, operation, troubleshooting, maintenance and cleaning.
- The operating company must ensure that all persons who work with machine, have read and understood this manual. Furthermore she must instruct the staff in regular intervals and inform them about the hazards.
- The operator must provide the necessary protective equipment to the staff and order the use of the necessary protective equipment in a binding way

Furthermore the operating company is responsible to keep the Machine always in a technically flawless state. Thus, the following applies:

- The operator must ensure that the maintenance intervals described in this manual are kept.
- The operator must have all safety devices checked regularly for their good working order and their integrity.

2.3 Qualification of personnel

The different tasks described in this manual represent different requirements to the qualification of the persons entrusted with these tasks.



WARNING!

Danger in case of insufficient qualification of the staff!

Insufficiently qualified persons cannot estimate the risks while using machine and expose themselves and others to the danger of severe injuries.

- Have all works only performed by qualified persons.
- Keep insufficiently qualified persons and children out of the working area.

Only persons reliable working procedures can be expected from, are allowed to perform all works. Persons the responsiveness of which is affected by e. g. drugs, alcohol or medication, are not allowed to work with the machine.

The qualifications of the personnel for the different tasks are mentioned below:

Operator:

The operator is instructed by the operating company about the assigned tasks and possible risks in case of improper behaviour. Any tasks which need to be performed beyond the operation in the standard mode must only be performed by the operator if it is indicated in these instructions and if the operating company expressly commissioned the operator.

Electrical specialist:

Due to his professional training, knowledge and experience as well as his knowledge of respective standards and regulations the electrical specialist is able to perform works on the electrical system and to recognise and avoid any possible dangers himself.

Specialist staff:

Due to their professional training, knowledge and experience as well as their knowledge of relevant regulations the specialist staff is able to perform the assigned tasks and to recognise and avoid any possible dangers themselves.

Manufacturer:

Certain works may only be performed by specialist personnel of the manufacturer. Other personnel is not authorized to perform these works. Please contact our customer service for the execution of all arising work.

2.4 Personal protective equipment

The personal protective equipment serves to protect persons against impairments of safety and health while working. The staff has to wear personal protective equipment while performing different works on and with grinding system which are indicated in the individual paragraphs of these instructions.

The personal protective equipment is explained in the following paragraph:



Hearing protection

Hearing protection helps to protect your hearing from harmful noise and other loud noises.



Eye protection

The protective goggles protect the eyes against parts flying off and splashes of liquids.



Breathing protection

The breathing protection serves for protecting the respiratory passages and the lung against the intake of dust particles.



Protective gloves

The protective gloves serve to protect the hands against sharp components as well as against friction, abrasions or deep injuries.



Safety boots

The safety boots protect the feet against crushes, falling parts and slipping over on slippery underground.



Protective clothes

The protective clothes are tight clothes of little tensile strength.

2.5 Safety signs on the Machine

The following safety signs and notes are applied on the grinding system (fig. 1), which need to be observed and followed.



Fig. 1: Safety signs

Damaged or missing safety symbols at the machine may lead to errors with personal and material damages. The safety symbols which are applied on the machine must not be removed. Damaged safety symbols must be replaced immediately.

The machine must be put out of operation from the moment when the labels are unable to be recognized and understood at first glance, until new labels are attached.

2.6 Regulations for safety and accident prevention

The following instructions are to be followed by the operating personnel.

- The noise level (sound pressure level) of this machine may exceed 82 dB (A) at the workplace. In this case, sound and hearing protection measures are required and used by the operator.



Ear protection

Please wear ear protection when working with the device.

- Before operating the machine, read the operating instructions.
- Never touch rotating or moving parts.
- Always report electrical faults to an electrician.
- Always keep work clothes, long hair, jewellery etc. away from the machine.
- Switch off machine when work is interrupted.
- Wear suitable safety clothing (accident prevention shoes, safety glasses, etc.).
- Check safety devices for correct function before starting work.
- Read and understand safety instructions attached to the machine.
- Perform regular maintenance.
- Do not overload the machine.
- If the machine is not operating normally, the supervisor must be informed immediately.

- Caution is advised when people are in the work area.
- Never change the electrical system.
- Never remove mechanical or electrical safety devices.
- Special attention is needed during transport or reconstruction; The transport regulations must be followed.

3 Intended Use

The Oscillating spindle sanding machine is used exclusively for sanding wood and wood-like materials (wood fiber board, chipboard, plywood boards, laminated and non-laminated boards, etc.). Grinding other materials can result in fire, injury or damage. Please pay attention to the instructions in the operating instructions as well as the information signs on the machine. It must be connected to a suitable extraction system. The spindle grinder is suitable for private use, in schools, craft shops, workshops and for home improvement, not for industrial use. Proper use also includes compliance with all information in this manual. Any use beyond the intended use or otherwise is considered misuse.



WARNING!

Danger in case of misuse!

Misuse of the Oscillating spindle sanding machine can lead to dangerous situations.

- Operate the belt and spindle grinder only in the power range specified in the technical data.
- Never bypass or override the safety devices.
- Never work on other materials than specified in the intended use.
- Only operate the belt and spindle grinder in a technically perfect condition.
- Never work on several workpieces at the same time.

Unauthorized modifications or changes to the belt and spindle grinder may void the CE conformity of the Machine and are prohibited.

The company Stürmer Maschinen GmbH assumes no liability for design and technical changes to the belt and spindle grinder.

The improper use of the Oscillating spindle sanding machine as well as the disregard of the safety regulations or the operating instructions exclude a liability of the manufacturer for resulting damage to persons or objects and will invalidate the guarantee!

4 Technical Data

4.1 Table

Type	OSS 100
Max. Grinding height	116 mm
Rating	450 W
Motor speed	10 000 rpm
Bed size	370 x 295 mm
Sanding device speed	2000 rpm
Oscillation stroke	16 rpm
Oscillation	58 rpm
Spindle Ø	12,7 mm
Sanding sleeve Ø [mm]	13, 19, 26, 38, 51, 76
Dimensions (LxBxH)	390 x 330 x 450 mm
Extraction port Ø	38 mm
Protection class	II
Weight	14 kg
Item number	5903500

4.2 Type plate

Spindelschleifer
Spindle sander



Typ Type	OSS 100	Serien-Nr. Serial no.	
Artikel-Nr. Item no.	5903500	Baujahr Year of manufacture	
Motorleistung Motor power	450 W	Netzanschluss Power connection	230 V ~ / 50 Hz
		Drehzahl Speed	2000 1/min

 **Stürmer Maschinen GmbH**
Dr.-Robert-Pfleger-Str. 26, 96103 Hallstadt
Deutschland / Germany

www.holzstar.de

Fig. 2: Type plate OSS 100

5 Transport, packaging, storage

5.1 Delivery and transport

Delivery

Check the Oscillating spindle sanding machine after delivery for visible transport damage. If you discover any damage to the Oscillating spindle sanding machine, immediately report it to the carrier or dealer.

Transport



CAUTION!

Injuries caused by parts falling over or off a forklift, pallet truck or transport vehicle.

Only use means of transport that can carry the total weight and are suitable for it.

Improper transport of individual devices, unsecured devices stacked on top of each other or next to each other in packed or already unpacked condition is accident-prone and can cause damage or malfunctions for which we do not grant any liability or guarantee.

Transport the scope of delivery secured against shifting or tilting with a sufficiently dimensioned industrial truck to the installation site.

General risks during internal transport



CAUTION: DANGER OF TIPPING!

The device may be lifted unsecured by a maximum of 2cm.

Employees must be outside the danger zone, the reach of loads. Warn employees and, if necessary, advise employees of the hazard.

Devices may only be transported by authorized and qualified persons. Act responsibly during transport and always consider the consequences. Refrain from daring and risky actions.

Gradients and descents (e.g. driveways, ramps and the like) are particularly dangerous. If such passages are unavoidable, special caution is required.

Before starting the transport check the transport route for possible danger points, unevenness and disturbances as well as for sufficient strength and load capacity.

Danger points, unevenness and disturbance points must be inspected before transport. The removal of danger spots, disturbances and unevenness at the time of transport by other employees leads to considerable dangers.

Careful planning of internal transport is therefore essential.

5.2 Packaging

All used packaging materials and packaging aids of the grinding system are recyclable and generally need to be transported to the material recycling.

Crush the packaging material made of cardboard and supply it to the waste paper collection.

The films are made of polyethylene (PE) and the upholstery parts are made of polystyrene (PS). These materials have to be delivered to a recycling station of the responsible dumping company.

5.3 Storage

The spindle sander must be thoroughly cleaned before storing in a dry, clean and frost-free environment. Cover the machine with a protective tarpaulin.

6 Scope of delivery and Accessories

6.1 Scope of delivery

Check the machine immediately after delivery for transport damage and shortages. To do this, remove all individual parts from the box and compare them with the following illustration.



Fig. 3: OSS 100 Scope of Delivery

6.2 Accessories

We recommend only using high quality original Holzstar accessories. Only with original accessories can a flawless operation and optimal work results be guaranteed.

- Table deposits
- Spindle discs
- Grinding rollers
- Abrasive sleeves Sets

7 Description

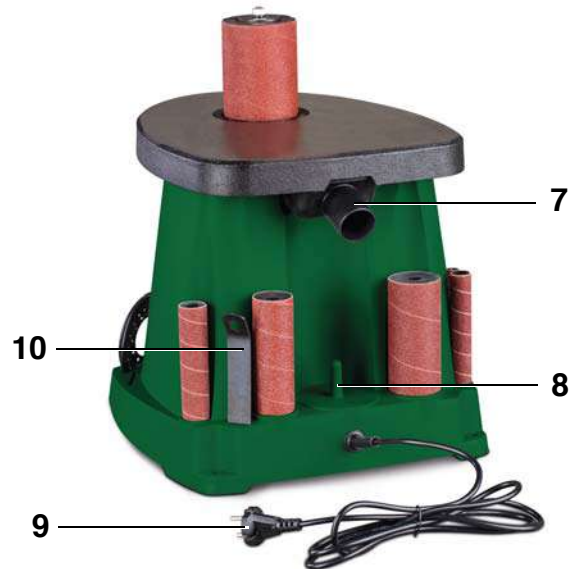

Fig. 4: Description

- 1 Clamping nut
- 2 Grinding sleeve
- 3 Work table
- 4 ON / OFF switch
- 5 Table inserts
- 6 Hole for anchoring
- 7 Suction nozzle (back)
- 8 Slot for grinding sleeve
- 9 Power plug
- 10 Clamping wrench SW 13
- 11 Sanding sleeve on sanding roller at the slot
- 12 Spindle disk

8 Assembly and Connection



DANGER!

Before starting any assembly work on the machine, it must be disconnected from the mains.

Handling and working with the machine is only permitted to persons who are familiar with the handling and operation of the machine.

Remove the machine from its packaging and remove all protective films. Make sure that the machine is not set up or put into operation in a damp or wet environment.

The humidity should not exceed 60% and the measured room temperature should be between 0 ° C and 40 ° C.

8.1 Fixing

Stationary use

For a safe footing, the machine should be mounted on a stable base (such as a workbench) using the holes provided in the machine base.

Mobile use

For mobile use of your grinding machine, mounting on a suitable base plate is recommended. This can then be clamped on the respective workbench. The base plate should be sufficiently stable and provide enough space for the mounting clamps.

8.2 Electrical connection



DANGER!

Danger to life due to electric shock!

There is danger to life when in contact with live components. Switched on electrical components can cause uncontrolled movements and lead to serious injuries.



DANGER!

All work on the electrical installation may only be carried out by a qualified electrician.

When making electrical connections, make sure that the characteristics (voltage, mains frequency, protection) match those on the rating plate and for the motor.

Operate the Oscillating spindle sanding machine only on an electrical supply, the following requirements.

Fulfills:

- The mains plug must be freely accessible.
- Use only a grounded receptacle (properly grounded receptacle).
- Lay the power cord so that it does not interfere with work and can not be damaged.
- Protect the power cord from heat, aggressive liquids and sharp edges.

The motor switches off automatically when overloaded. After a cooling time (different times), the engine can be switched on again. First, the cause of the overload must be resolved.

8.3 Connection for extraction system

When used in closed rooms, the machine must be connected to an exhaust system. The flow velocity at the extraction nozzle must be min. 20 m / s.

Mount the extraction hose of the extraction system on the extraction nozzle on the back of the grinding machine (suction nozzle diameter 38 mm).

8.4 Mounting the tool



DANGER!

Before changing tools, the machine must be switched off and disconnected from the mains. Pay attention to the cleanliness of the tools.

Step 1: Prepare the appropriate tools.

Step 2: Check that the machine is switched off and disconnected from the mains.

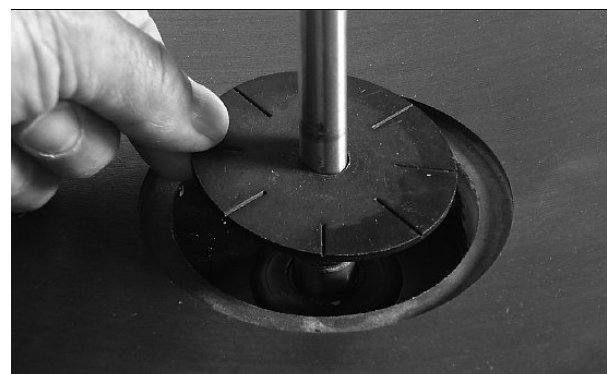

Fig. 5: Insert lower spindle disc

Step 3: Place the lower spindle disc on the spindle and push it downwards.

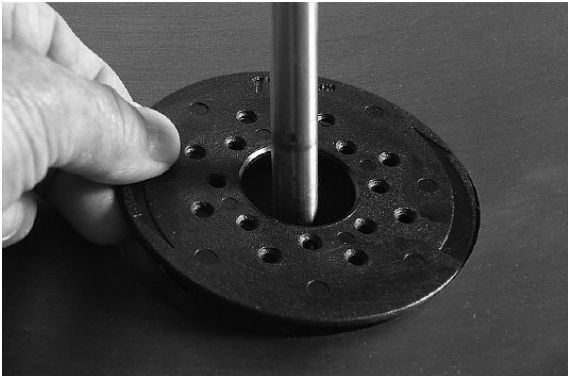

Fig. 6: Mounting the table Insert

Step 4: Insert the table insert, which fits the diameter of the grinding sleeve to be used, into the table. The hole of the table insert must be larger than the outside diameter of the grinding sleeve.



Fig. 7: Put on the sanding roller

Step 5: Place the sanding roller on the spindle.



Fig. 8: Place grinding sleeve on sanding roller

Step 6: Place the appropriate sanding sleeve on the sanding roller.



NOTE!

The grinding sleeve 13 mm is placed directly on the spindle.

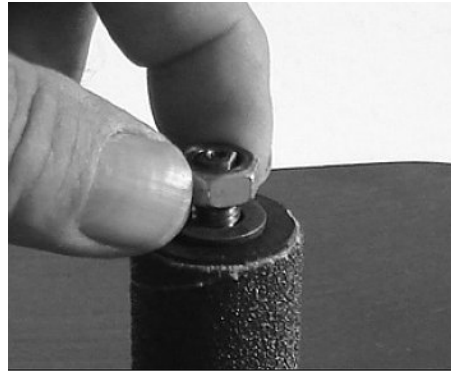

Fig. 9: Place spindle washer and screw on nut

Step 7: Fit the appropriate spindle disc and screw the clamping nut onto the spindle.

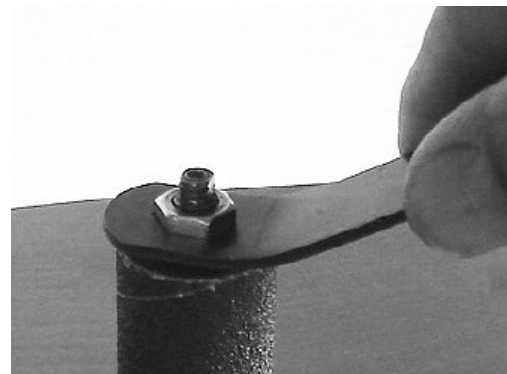

Fig. 10: Tighten the nut

Step 8: Tighten the nut with the wrench.

Sanding sleeve D Inside [mm]	Table insert D Inside [mm]	Spindle disc D Outer [mm]
13	18	16
19	25	20
26	31	20
38	44	35
51	57	35
76	82	35

9 Working with the machine

9.1 General

Please observe the following working instructions so that your work has the expected success.



DANGER!

Certain types of wood and wood products produce harmful dust emissions when processed. Therefore, only use your machine in a well-ventilated area, use a suction device and wear respiratory protection.



DANGER!

Rotating parts! Get to work with reason. Pay special attention to the rotating parts. Wear tight-fitting clothing. Make sure that hair or clothes are not caught by rotating parts! If necessary, wear a hairnet. When working with the machine no jewelry may be worn.



DANGER!

Flying chips and parts to be thrown off! Be sure to wear eye protection! Protect your eyes from flying chips.



CAUTION!

Keep children and unauthorized persons away from the work area.



WARNING!

Do not overload the machine.



Wear safety glasses



Wear a dust mask



Wear ear protection!

Before each start of work the following tests have to be carried out:

- Check all cables and plugs.
- Note that there are different grit sizes for sanding belts and sleeves for different jobs.
- Before starting the machine, make sure that the sanding belt or the grinding sleeve runs freely and is not braked or blocked by any workpieces.

9.2 Workflow

The machine is switched off, disconnected from the power supply, the extraction system is connected to the extraction nozzle and the desired grinding sleeve is mounted.

Step 1: Plug the mains plug of the suction unit and the spindle grinder into the socket.

Step 2: Switch on the extraction system.

Step 3: Switch on the spindle grinder.

Step 4: Machining the workpiece: Place the workpiece on the work table, hold the workpiece firmly with both hands, and apply light pressure to the grinding sleeve.



DANGER!

Do not work with too much pressure, otherwise the sanding sleeve wears too quickly. Never put your fingers in contact with the grinding sleeve!

Observe correct working direction! Only guide the workpiece against the direction of rotation of the grinding sleeve.

Step 5: After the end of work: Switch off the machine and pull out the mains plug. Switch off the extraction system and pull out the mains plug.

9.3 Notes for the grinding process

When grinding, pay attention to the safety instructions and use your personal protective equipment (protective goggles, ear protection, safety shoes, etc.).

- When grinding with the material, do not over-press against the grinding sleeve.
- Since the machine has no clamping option, it is important that your workpiece is resting on the worktable over the entire surface and can be held firmly!
- Never sand an unsupported workpiece. Support the workpiece with the table.

- When working on large workpieces, you should use additional support at table height.
- Never grind workpieces that are too small for safe operation.
- Always remove debris and other pieces from the table or sanding sleeve before turning on the machine.
- Make sure that the sanding sleeve is in good condition and replace worn abrasive sleeves in good time. Only with perfect tools you can achieve a good grinding quality!
- Never leave the work area when the machine is switched on or the tool has not come to a complete stop.

10 Care, maintenance and repair



DANGER!

Danger to live due to electrical voltage!

Contact with live components can be fatal. Activated electrical components can execute uncontrolled movements and cause serious injuries.

- Switch off the machine before carrying out cleaning and maintenance work and unplug the power cord.
- Connections and repairs of electrical equipment may only be performed by a qualified electrician.

10.1 Cleaning



Wearing safety gloves!



Wear protective clothing!



NOTE!

Never use strong detergents for all cleaning work. This can lead to damage or destruction of the device.

Basically, the machine should be cleaned after each use. With the machine off, remove the chips and dust with a hand brush or brush.



DANGER!

Do not remove the chips with bare hands. There is a risk of cuts due to chips and tools!



DANGER!

There must be no water inside the device!

10.2 Maintenance

Maintenance and repair work must be carried out by qualified personnel only and should be repeated regularly to maintain the performance of the machine.

If the Oscillating spindle sanding machine does not work properly, contact a dealer or our customer service. The contact details can be found in chapter 1.2 Customer Service.



NOTE!

- Check the grinding belt or the grinding sleeves regularly for errors. Replace a damaged sanding belt or sanding sleeve immediately.
- Check the correct setting of the tape guide at regular intervals. Relax the sanding belt during longer work breaks. Clean the machine at regular intervals.
- Check the adequate function of the extraction daily.
- Replace damaged safety equipment immediately.
- Connections and repairs of the electrical equipment may only be carried out by a qualified electrician

11 Troubleshooting

Fault	Possible causes	Elimination
Engine is not running	<ol style="list-style-type: none"> 1. Damaged ON / OFF switch 2. Damaged ON / OFF switch lead 3. Relay damaged 4. Engine defective 5. Fuses defective 	Check the machine by an electrician and replace the damaged parts
Machine slows down while working	It is worked with too much pressure	Apply less pressure on the workpiece
Low service life of the abrasives	Abrasive with too fine grain	Use coarse grain abrasives
Bad sanding picture	Abrasive with too coarse grain	Use finer grained abrasive
Wood burns during grinding	Grinding sleeve or abrasive belt is coated with lubricant. There is too much pressure on the workpiece	Replace the sanding sleeve or sanding belt. Reduce the pressure on the workpiece.
Strong vibration	<ol style="list-style-type: none"> 1. Grinding sleeve or grinding belt loosely mounted 2. Sanding sleeve or sanding roller or sanding belt defective 3. Spindle beats 	<ol style="list-style-type: none"> 1. Clamp the grinding sleeve or sanding belt 2. Replace grinding sleeve or sanding roller or sanding belt. 3. Repair by the service

12 Disposal instructions / Recycling options

Dispose of your device in an environmentally friendly, by not disposing of waste in the environment but professionally.

Please take the packaging and later the old appliance does not just go away, but discard them in accordance with the relevant of your city / municipality or by the waste disposal company established guidelines.

12.1 Decommission

Discarded appliances are immediately professionally decommission, in order to avoid any later misuse and the threat to the environment or people.

Step 1: Remove all environmentally hazardous materials from the old device.

Step 2: Remove the machine optionally into manageable and actionable assemblies and components.

Step 3: Leading the machine components and supplies the appropriate disposal routes.

12.2 Disposal of new equipment packaging

All used packaging materials and packaging aids of the machine are recyclable and must always be recycled.

The packaging wood can be sent for disposal or recycling.

Packaging components made of cardboard can be crushed for waste paper collection.

The foils are made of polyethylene (PE) or the upholstery parts made of polystyrene (PS). These substances can be reused after processing if they are passed on to a recycling center or to the disposal company responsible for them.

Only pass on the packaging material in such a way that it can be directly recycled.

12.3 Disposal of electrical appliances



NOTE!

Please take care in your interest and in the interest of the environment that all components of the machine are disposed according to the rules.

Please note that electrical units contain a variety of recyclable materials and environmentally harmful components.

Please contribute that these components are separated and disposed of properly. If in doubt, contact your municipal waste.

For preparation for commissioning please contact a company specialized for disposal.

12.4 Disposal of lubricants



DANGER!

Please pay attention to an environmentally friendly disposal of the used lubricants. Observe the disposal instructions of your municipal disposal companies.

The disposal instructions for the lubricants used are provided by the lubricant manufacturer. If necessary, ask for the productspecific data sheets.

12.5 Disposal via municipal collection points

Disposal of used electrical and electronic equipment (Applicable in the countries of the European Union and other European countries with a separate collection system for these appliances).



The symbol on the product or its packaging indicates that this product should not be treated as normal household waste but must be returned to a collection point for the recycling of electrical and electronic equipment.

By helping to properly dispose of this product, you are protecting the environment and health of others. Environment and health are at risk from improper disposal. Material recycling helps reduce the consumption of raw materials. For more information on recycling this product, contact your local community, municipal waste disposal service or the shop where you purchased the product.

13 Spare parts



DANGER!

Danger of injury by the use of wrong spare parts!

Dangers may result for the user and damages as well as malfunctions may be caused by using wrong or damaged spare parts.

- Only use original spare parts of the manufacturer or spare parts admitted by the manufacturer.
- Always contact the manufacturer in case of uncertainties.



Tips and recommendations

Using non-approved spare parts voids the manufacturer's warranty.

13.1 Ordering spare parts

The spare parts may be purchased with the authorised dealer or directly with the manufacturer. Please find the corresponding contact data in Chapter 1.2 Customer service.

Indicate the following basic information for spare part orders:

- Type of device
- Serial number
- Quantity
- Designation
- Required mode of dispatch (mail, freight, sea, air, express)
- Address of dispatch

Spare part orders which do not include the above indications may not be taken into consideration. If the indications regarding the mode of dispatch are missing, the product is dispatched at the discretion of the supplier.

Information on the device type, item number and year of manufacture can be found on the typeplate, which is attached to the unit.

Example

The spindle for the Oscillating spindle sanding machine OSS 100 must be ordered. The spindle has the number 54 in the spare parts drawing 1.

By ordering spare parts, send a copy of the spare parts drawing (1) with the marked part (spindle) and marked position number (54) to the dealer or spare parts department and provide the following information:

- Type of device: **Oscillating spindle sanding machine**
- Item number: **5903500**
- Position No: **54**
- Drawing number: **1**

13.2 Spare Parts Drawing

The following drawing is intended to help in case of service, to identify necessary spare parts. To order send a copy of the parts drawing with marked components to your dealer.

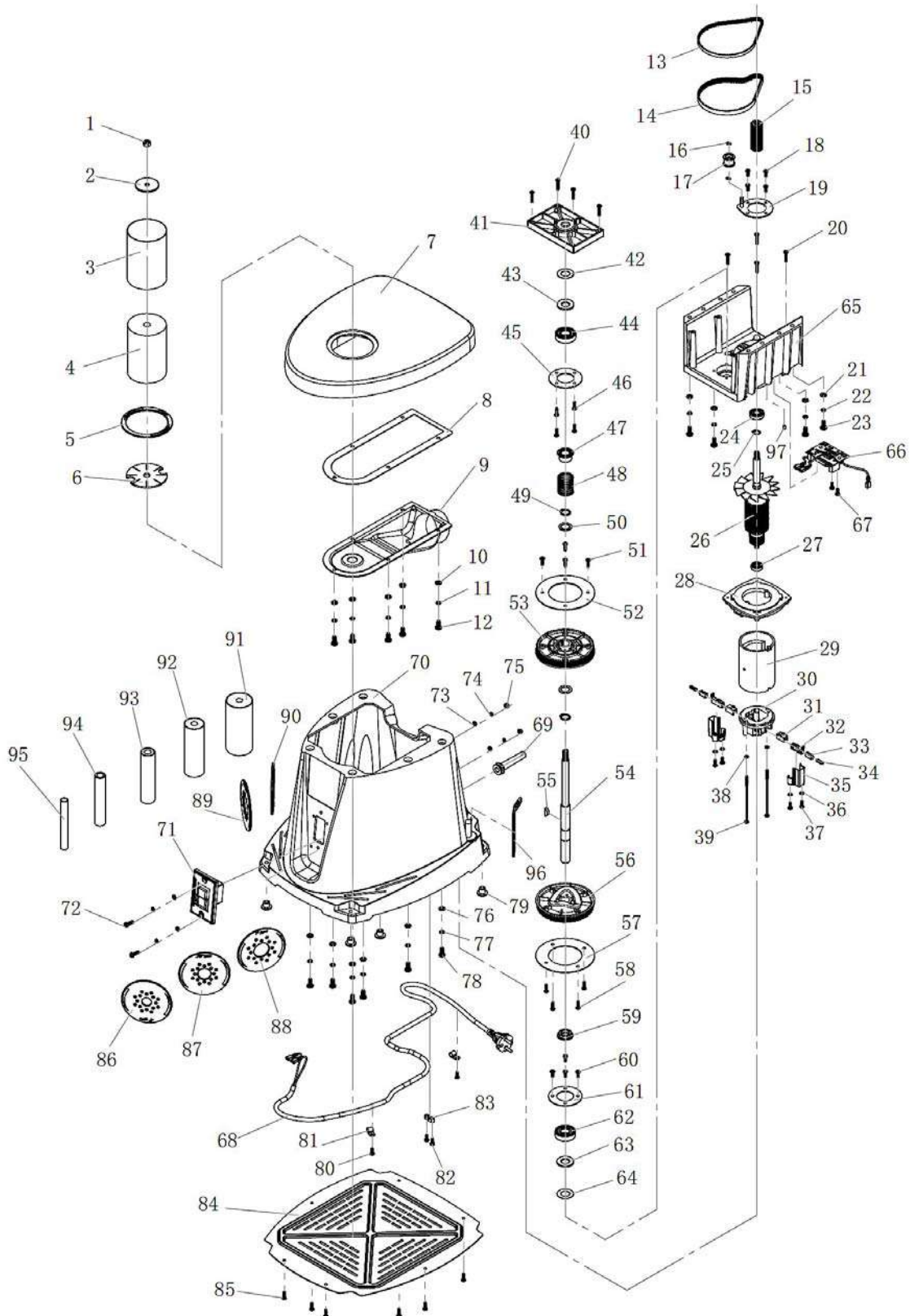

Fig. 11: Spare parts Drawing OSS 100

14 EC Declaration of Conformity

According to Machinery Directive 2006/42/EC Annex II 1.A

Manufacturer / distributor: Stürmer Maschinen GmbH
Dr.-Robert-Pfleger-Str. 26
D-96103 Hallstadt

hereby declares that the following product

Product Group: Holzstar® Wood working machines
Machine typ: Oscillating spindle sanding machine
Description of the machine: OSS 100
Item Number: 5903500
Serial Number*: _____
Year of manufacture*: 20_____

* please fill in according to the information on the type plate

corresponds to all the relevant provisions of the abovementioned Directive and other Directives applied (below) - including their amendments current at the time of the declaration.

Relevant EU Directive: 2014/30/EU EMC-Directive
2012/19/EU WEEE-Directive

The following harmonized standards were applied:

DIN EN 62841-1:2015 Electric motor-operated hand-held tools, transportable tools and lawn and garden machinery - Safety - Part 1: General requirements
DIN ISO 12100 -1:2010 Safety of machinery. General principles for design Risk assessment and risk reduction (ISO 12100:2010)

Responsible for documentation: Kilian Stürmer, Dr.-Robert-Pfleger-Str. 26, D-96103 Hallstadt

Hallstadt, den 11.01.2017



Kilian Stürmer
Manager



15 Notes

