



Woodworking machinery at its best!

SPINDLE MOULDER OWNERS MANUAL

MODELS: W050 & W050P



A 16 amp fixed electric supply is required to run this machine.

Recommended breaker size:
16 Amps (Type C)



Charnwood, Cedar Court, Walker Road,
Hilltop Industrial Estate, Bardon Hill, Leicestershire, LE67 1TU

Tel. 01530 516 926 Fax. 01530 516 929
email: sales@charnwood.net website: www.charnwood.net

Forward

These instructions are important, the information contained herein is essential for the correct build and operation of the machine and the safety of its operator.

The machine is equipped with various safety devices to protect itself and the operator. However, these devices cannot cover all eventualities and a thorough understanding of spindle moulding techniques, good workshop practice plus the controls and operation of this machine are essential for your safety.

Do not operate the machine until you have read and understood all the instructions in this manual and are familiar with both the machine and spindle moulding techniques.

Use of the Machine

This machine is designed for moulding along and across the grain of prepared timber, using cutters and limiters, correctly mounted in a standard Euro type cutter block.

It is designed for use by one operator.

Operator Qualifications/Training

Operators of this machine should have a suitable qualification in the use of woodworking machinery, including spindle moulders or should have been trained by someone holding such qualifications.

GENERAL SAFETY RULES



WARNING: Do not attempt to operate the machine until you have read thoroughly and understood completely all instructions, rules, etc. contained in this manual. Failure to comply may result in accidents involving fire, electric shock, or serious personal injury. Keep this owner's manual and review it frequently for continuous safe operation.

1. Know your machine. For your own safety, read the owner's manual carefully. Learn its application and limitations, as well as specific potential hazards pertinent to this machine.
2. Make sure all tools are properly earthed.
3. Keep guards in place and in working order. If a guard must be removed for maintenance or cleaning, make sure it is properly replaced before using the machine again.
4. Remove adjusting keys and spanners. Form a habit of checking to see that the keys and adjusting spanners are removed from the machine before switched it on.
5. Keep your work area clean. Cluttered areas and workbenches increase the chance of an accident.'
6. Do not use in dangerous environments. Do not use power tools in damp or wet locations, or expose them to rain. Keep work areas well illuminated.
7. Keep children away. All visitors should be kept a safe distance from the work area.
8. Make workshop childproof. Use padlocks, master switches and remove starter keys.
9. Do not force the machine. It will do the job better and be safer, at the rate for which it is designed.

10. Use the right tools. Do not force the machine or attachments to do a job for which they are not designed. Contact the manufacturer or distributor if there is any question about the machine's suitability for a particular job.
11. Wear proper apparel. Avoid loose clothing, gloves, ties, rings, bracelets, and jewellery which could get caught in moving parts. Non-slip footwear is recommended. Wear protective hair covering to contain long hair.
12. Always use safety glasses. Normal spectacles only have impact resistant lenses. They are not safety glasses.
13. Do not over-reach. Keep proper footing and balance at all times.
14. Maintain machine in good condition. Keep machine clean for best and safest performance. Follow instructions for lubrication and changing accessories.
15. Disconnect the machine from its power source before servicing and when changing accessories.
16. To avoid accidental starting, make sure the switch is in the OFF position before plugging in the mains cable.
17. Never leave the machine running unattended. Turn the power off. Do not leave the machine until it comes to a complete stop.
18. Do not use any power tools while under the effects of drugs, alcohol or medication.
19. Always wear a face or dust mask if operation creates a lot of dust and/or chips. Always operate the tool in a well ventilated area and provide for proper dust removal. Use a suitable dust extractor.

EXTRA RULES FOR SPINDLE MOULDERS

1. A spindle moulder should never be used by an untrained operator. Proper training is essential for the operator's safety.
2. The machine must be properly maintained and the correct fitting of all guards checked.
3. Guards should be of such a design and fitted in such a way that they keep fingers out of an area of 50 mm (2 inches) beyond the sweep of any cutter that might be used.
4. Always ensure that you use safe working procedures and that you understand what you are doing.
5. Wear appropriate clothing. Long loose sleeves, long hair or anything else that could get caught in the machine should be tied back or otherwise secured.
6. Never use this spindle moulder for curved work, without a Ring Fence fitted.
7. **NEVER** use a cutter block without limiters.
8. Feed the workpiece to the cutter block or router bit against the direction of rotation.
9. Never draw the workpiece back during cutting. Wait until the block stops rotating before pulling the workpiece back.



Risk of injury!
Never reach into
moving tooling.



Wear Eye
Protection



Wear Ear
Protection

Charnwood W050 Specification

Main table surface	1000 x 360mm
Sliding table size	1000 x 240mm
Sliding carriage stroke	1200mm
Table height	900mm
Spindle diameter	30mm
Spindle Tilt	+5 to – 45 degrees
Maximum Tooling Diameter (Above Table)	200mm
Maximum Tooling Diameter (Below Table)	180mm
Rotation speeds	4(1800/3000/6000/9000) rpm
Spindle rise and fall	100mm
Table aperture depth	50mm
Motor (induction)	240V, 1500W (2hp) single phase
Recommended breaker size (MCB)	16 Amps (Type C)
Extractor outlet	100mm
Rating	Trade
Product Guarantee	5 years
Weight Net / Gross	218kg / 270kg

Rating

Trade: Suitable for daily use by professional woodworkers.

Continuously rated, high power and a heavy duty construction. Typically used by several different operators in a small or medium sized business. Will be used up to the machines maximum limit with some long work periods.

Expected maximum use of 1000 hours annually.

Unpacking



This product is shipped in a wooden crate.

To open the wooden crate cut the vertical straps and lift the lid of the crate from the base.

Remove the carton from the side of the machine.

Remove the Table insert rings from the top of the table.



Lift the machine off from the base.

The final carton is stored underneath the machine.

Peel off the protective paper from the cast Iron table and clean it using WD40 or similar.

Peel off the protective film from the sliding carriage

Please Note: Do not dispose of any packaging until the machine has been fully assembled and tested. In the unlikely event of a problem which requires the product to be returned, the packaging will need to be re-used.

Open the remaining cartons, unpack all the components and check everything is present.

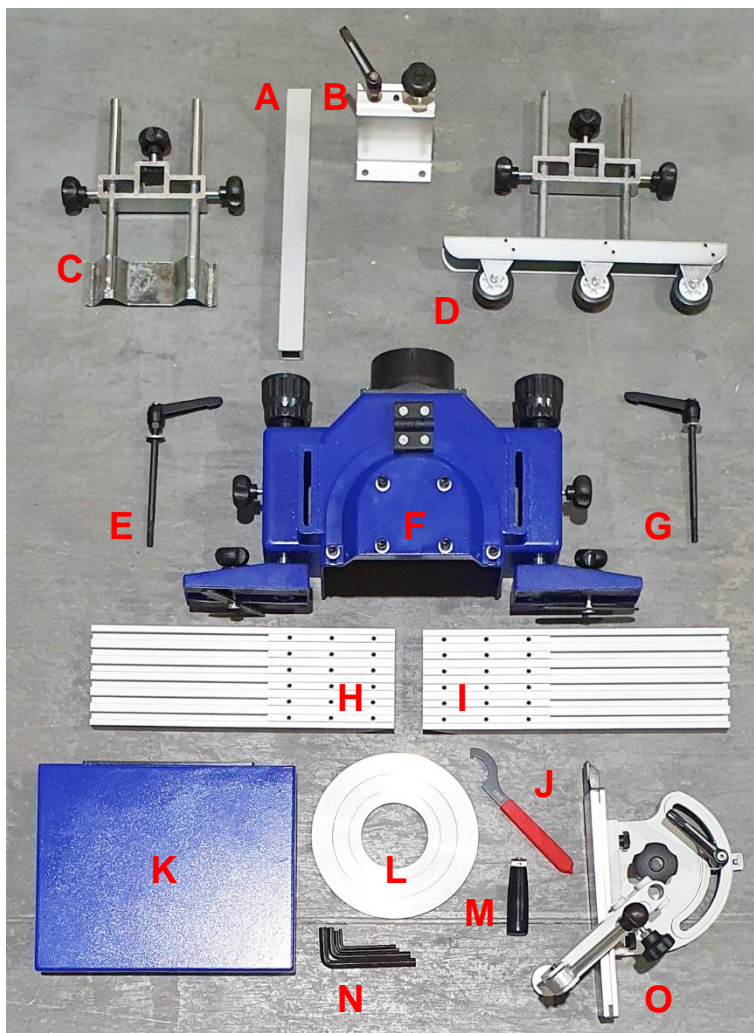

- A)** Square Tube
- B)** Guard Support
- C)** Front Guard
- D)** Feed Rollers
- E)** Locking Handle
- F)** Cutter Hood
- G)** Locking Handle
- H)** Left Fence
- I)** Right Fence
- J)** Cutter Block Tool
- K)** Support Table
- L)** Table Insert Rings
- M)** Carriage Handle
- N)** Service Tools
- O)** Mitre Fence

Assembly

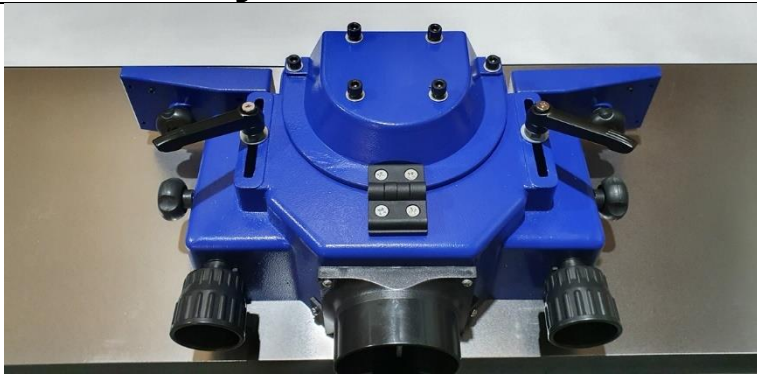

Fit The Cutter Hood

Fit the Hood onto the table

Secure it by locating the 2 long ratchet handles into 2 threaded holes in the table

There are 2 pairs of holes to allow the Hood to be set forwards or backwards relative to the spindle

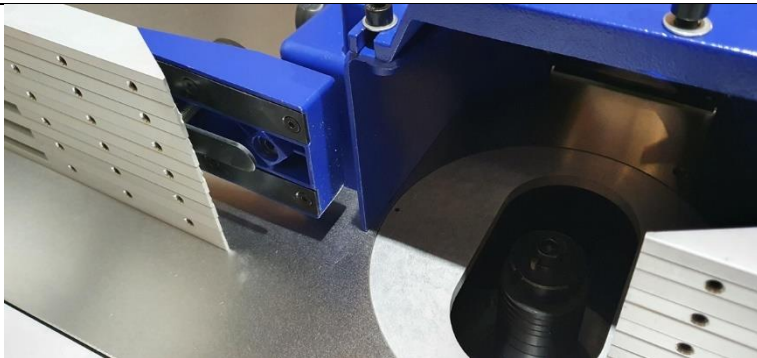

Fit The Fences

Slide the fence, bevelled end first, over the guide plate

The fences can be adjusted in and out to close the gap to the cutters

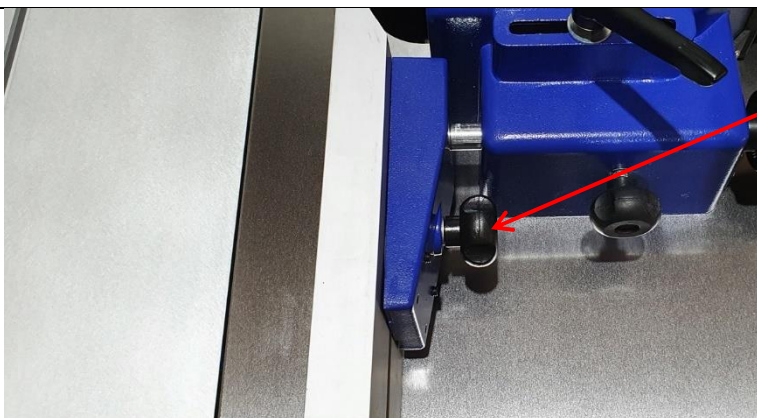

When the fences are in the desired position, lock them in place with the Fence Locking Knob

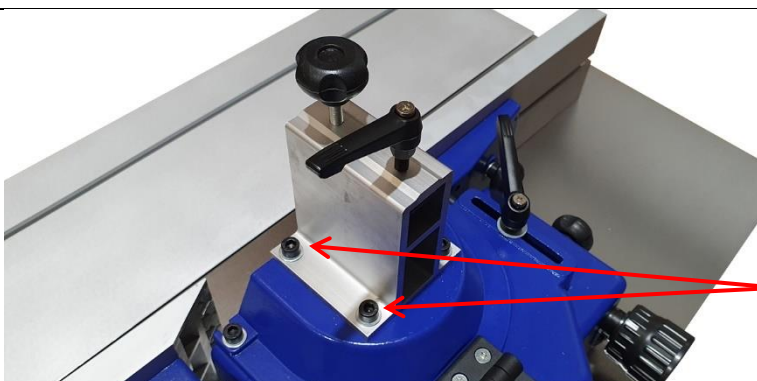

Fit the Guard Support

Use a 6mm Allen key to remove 4 bolts in the top of the Hood

Place the guard Support onto the Hood

Re-fit the 4 bolts.

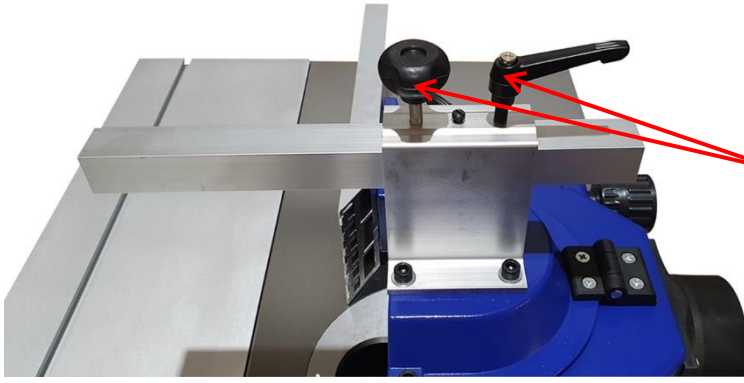

Fit the Square Tube

Slide the square tube into the support

Lock it in place using both locking handles

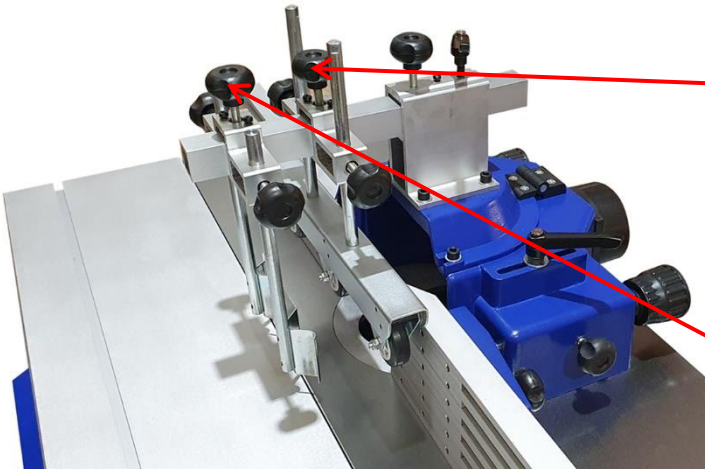

Fit The Feed Rollers

Slide the Feed Rollers onto the Square Tube and secure using the locking knob

Fit the Front guard

Slide the Front Guard onto the Square Tube and secure using the locking knob

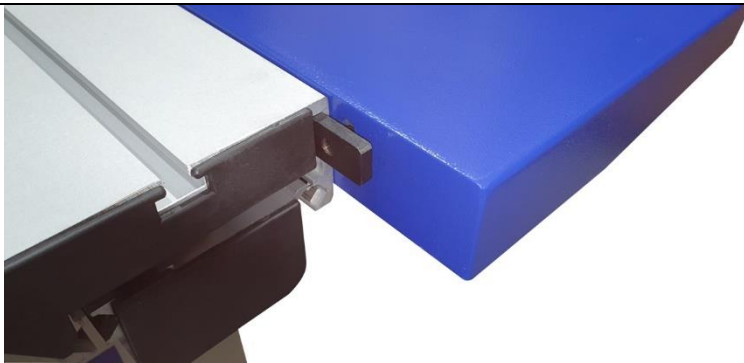

Fit The Support Table

The table fits onto the front edge of the sliding carriage

From the left end, insert the Support Table guide plate into the extrusion

Move it along the sliding carriage and lock it into place using the 2 ratchet levers

Ensure the top surface of the table is flush with the top of the sliding carriage

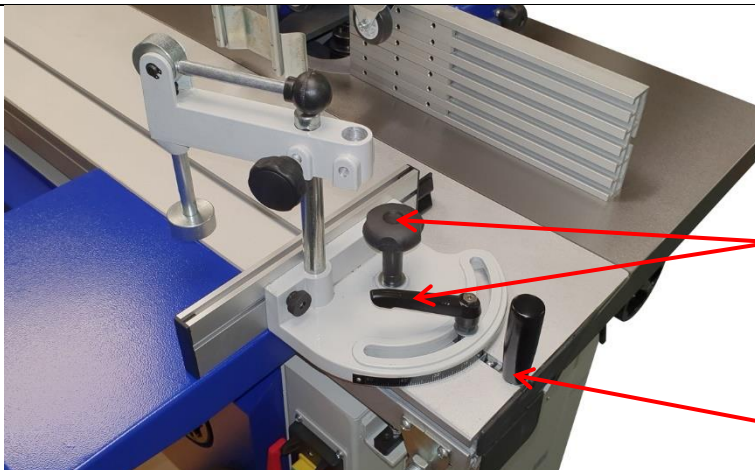

Fit the Mitre Fence

Take the mitre fence and fit the guide bar into the T slot running along the length of the sliding carriage

Lock it in place using the pivot lock and the angle lock.

Fit The Carriage Handle

Slide the handle into the same extrusion and rotate it to lock it

Using The Spindle Moulder

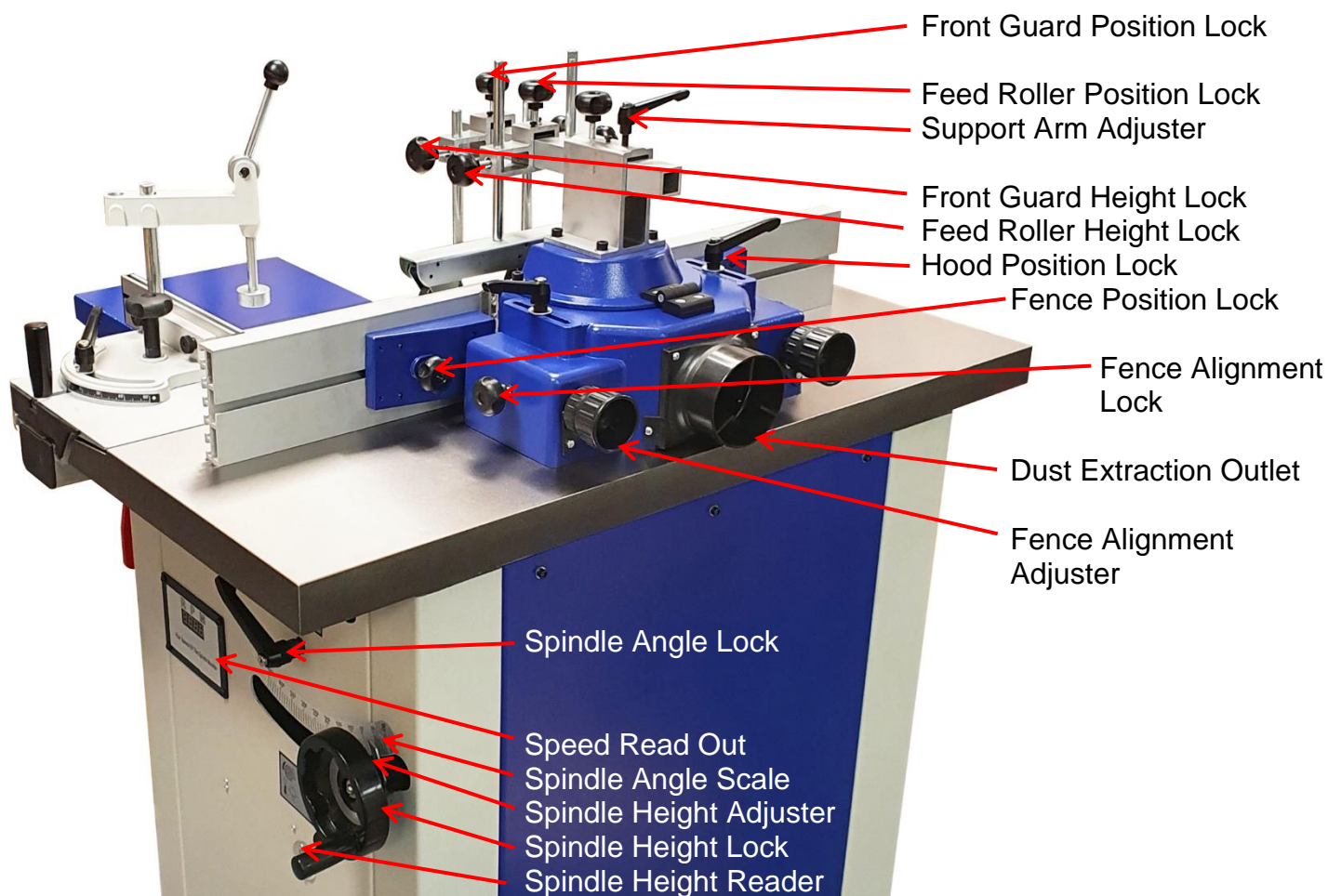

Fitting a Cutter block

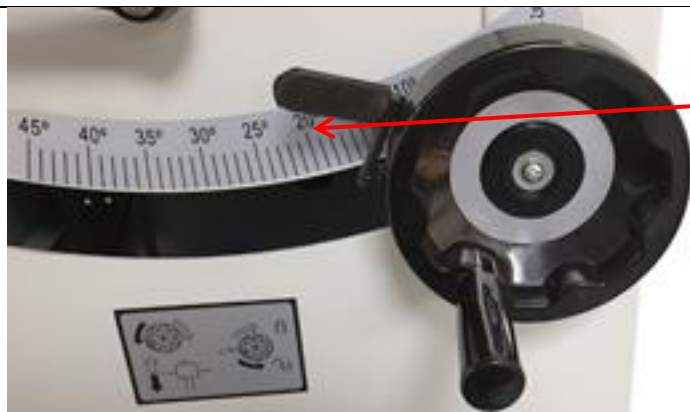

Raise the Spindle

Spindle Height Lock

Disengage the spindle height lock by rotating the lever anticlockwise.

Turn the handwheel clockwise to raise the spindle.

Disconnect from the Power Supply



Empty the spindle

Use an 8mm Allen key and the C spanner provided, to undo the Locking Bolt from the top of the spindle. Holding the spindle stationary with the spanner, turn the Allen key Anticlockwise to undo the bolt

Remove the Locking Cap and Spacer Set from the spindle

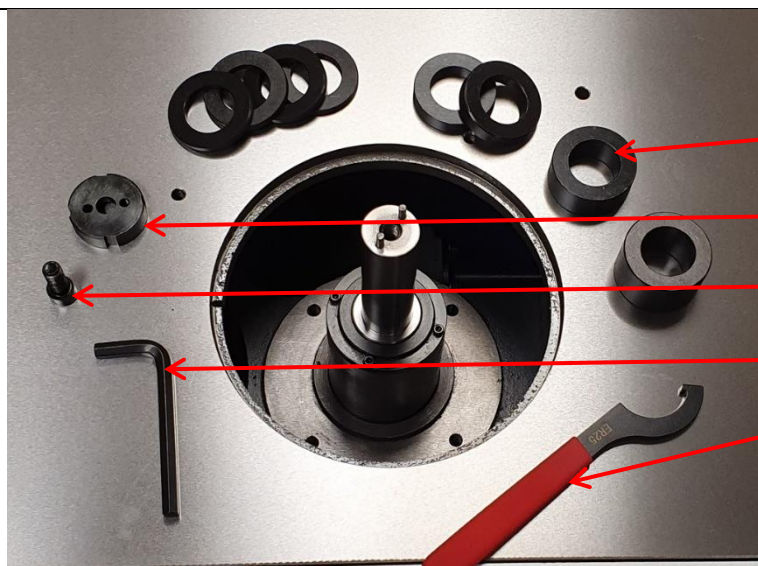

Spindle Components

Spacer Set

Locking Cap

Locking Bolt

8mm Allen Key

C Spanner



Fit the Cutter Block

Fit the cutter block onto the spindle as low as possible. Be sure to check the direction of rotation of the cutter block (When set to 'L' the spindle runs anticlockwise)

Fit spacers back onto the spindle until the top of the spacer stack is within 5mm of the top of the spindle.

Fit the Locking Cap and tighten the Locking Bolt



Fit the Table Insert Rings

Fit the Inserts to close up the aperture much as possible

The insert rings close the aperture from 190mm to: 130mm, 100mm & 80mm

The elongated insert should be used when tilting the spindle

Changing The Spindle Speed

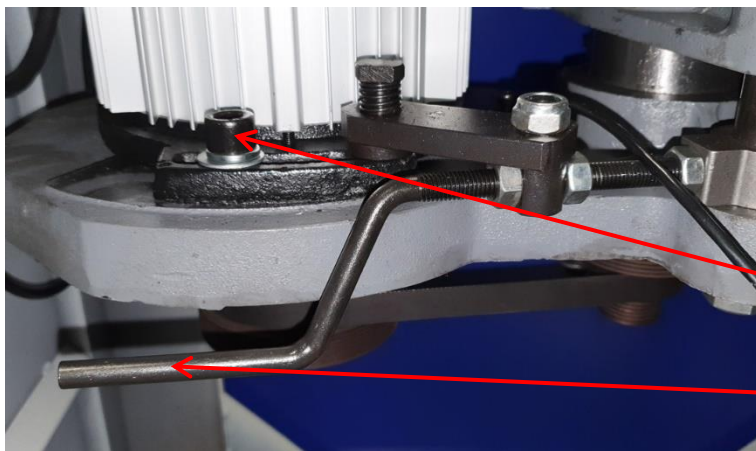

Disconnect from the power supply

Open the access door by using a 4mm Allen key to remove 2 bolts. The door is fitted with a cut out switch to prevent running when the door is open.

Use a 10mm Allen key to loosen the locking bolt

Pull the tensioning lever towards you to slacken the tension on the drive belt

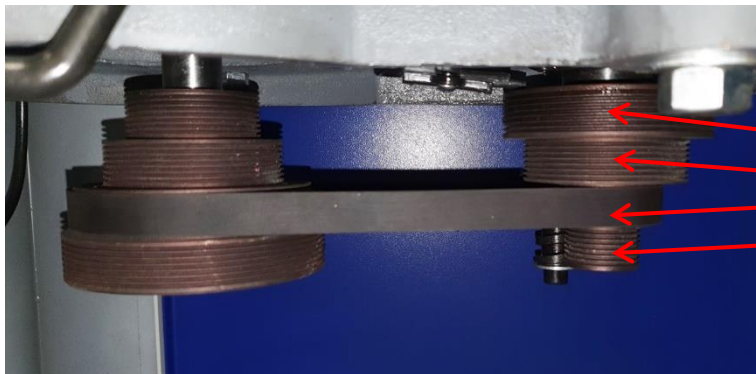

Move the drive belt onto the appropriate pulley pair to get the desired speed

9000rpm

6000rpm

3000rpm

1800rpm

Re-tension the drive belt, tighten the locking bolt, close the access door



Speed Display

The current spindle speed can be read in RPM from the digital read out when the machine is powered up.

Operating the Spindle Moulder

It is assumed that anyone purchasing a spindle moulder has been trained to operate this type of machine competently. Such training is beyond the scope of this manual.

Setting the fences

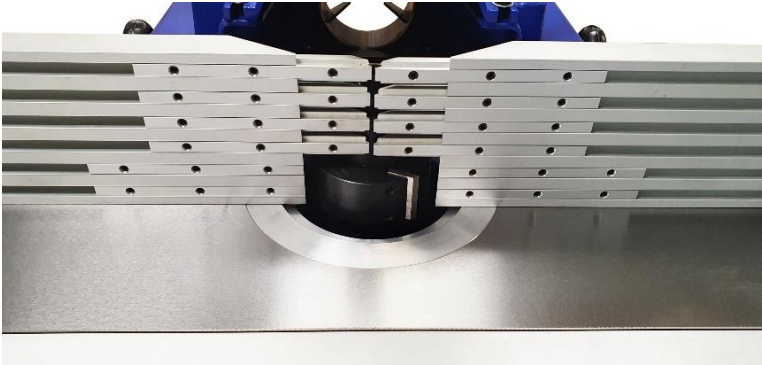

Both of the fences are adjustable in two directions.

When the machine operation will not remove the complete face of the workpiece: Take a long straight edge and check the 2 fences are aligned. If they are not, undo one of the Fence Alignment Locks and then use the Fence Alignment Adjuster to move the fence until both are aligned.

Undo the Fence Position Lock and slide

the two fences towards the cutter until there is a gap of around 5mm.

The fences are fitted with integrated fingers to further close the fence around the cutter block. Use a 3mm Allen key to release and then slide the integrated fingers towards the cutters.

Set the Feed Roller and Front Guard

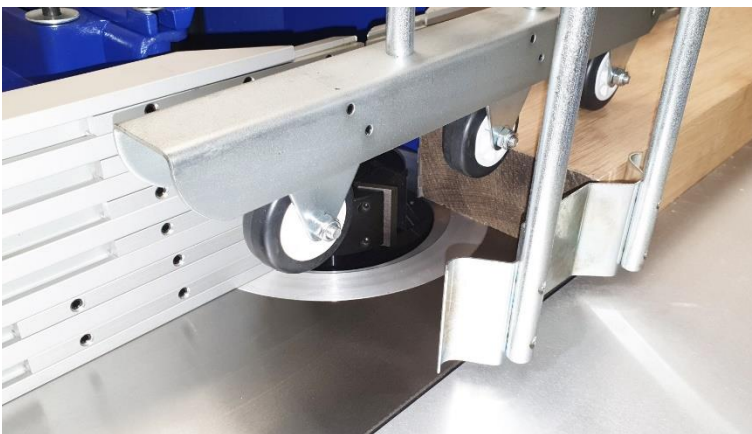

Adjust the position of the Feed Roller by loosening the Position Lock knob and moving the rollers to the centre of the workpiece. Then undo the two Height Lock knobs and set the height so that the rollers are in contact with the workpiece.

Adjust the position of the Front Guard so that it contacts the front face of the workpiece. Adjust the height of the Front Guard so the bottom edge is 5mm above the work table.

Setting the sliding carriage

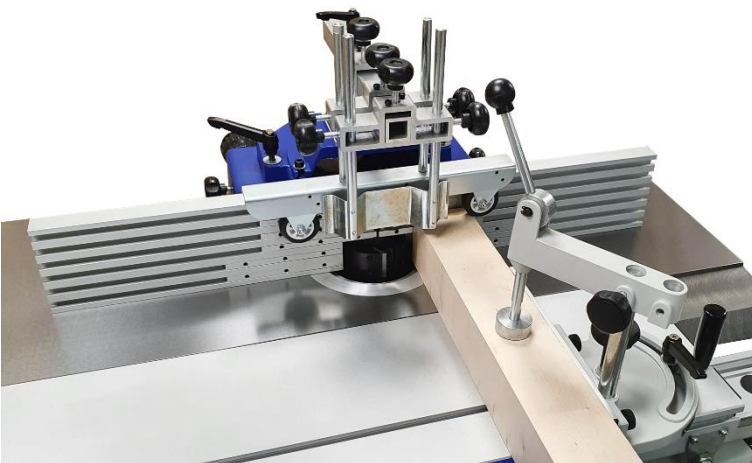

To use the sliding carriage first undo the Carriage Lock. Pull the knob towards you, rotate 90 degrees and release. The spring loaded plunger is now held in the open position.

The Mitre Fence is normally set at 90 degrees to the direction of travel. To change the angle of the fence, loosen both the Pivot Lock and the angle lock. Set the angle from the scale and tighten both locks.

The work clamp can be used to secure the workpiece on the work table. Set the height

of the clamp to within 5mm of the top surface of the work piece. Raise the lever into the vertical position to engage the clamp.

Set the Spindle Height



Disengage the spindle height lock by rotating the locking lever anticlockwise. Turn the handwheel clockwise to raise the spindle. The spindle height can be read from the scale.

Set the Spindle Tilt



To adjust the spindle from the standard 90 degree position, turn the Spindle Angle Lock anticlockwise to release the spindle, then rotate the Spindle Angle Adjuster handwheel to set the desired angle. Turn anticlockwise to tilt the spindle back, up to -45 degrees. Turn the handwheel clockwise to tilt the spindle forwards, up to +5degrees. Read from the scale and lock the angle when set.

Starting the machine

First choose the spindle rotation direction. Turning the selector switch to the Left 'L' position is the regular direction. Cutters spin anticlockwise and feed direction is right to left when viewed from the front of the machine.

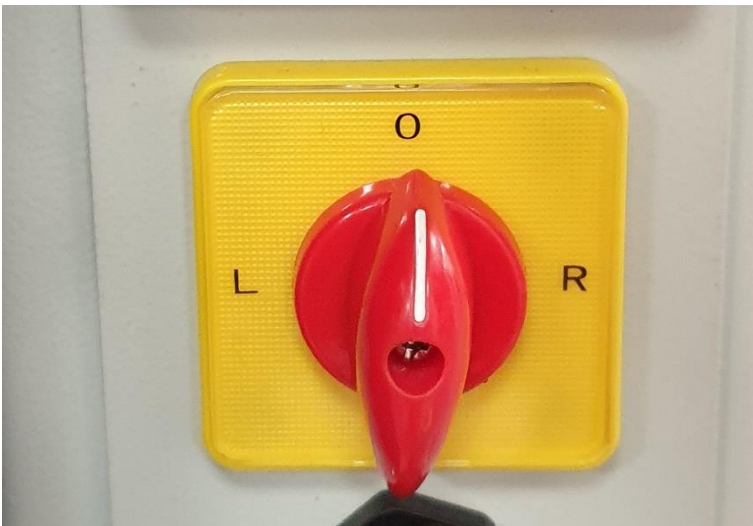

If you have made any adjustment to the cutter block, the speed, the fences or the guard - Start the machine with a quick 'On/Off' burst, to check the cutters are not making contact anywhere. Once satisfied, start the machine and allow the cutters to get up to full rotation speed before making a cut.

Workpiece Handling

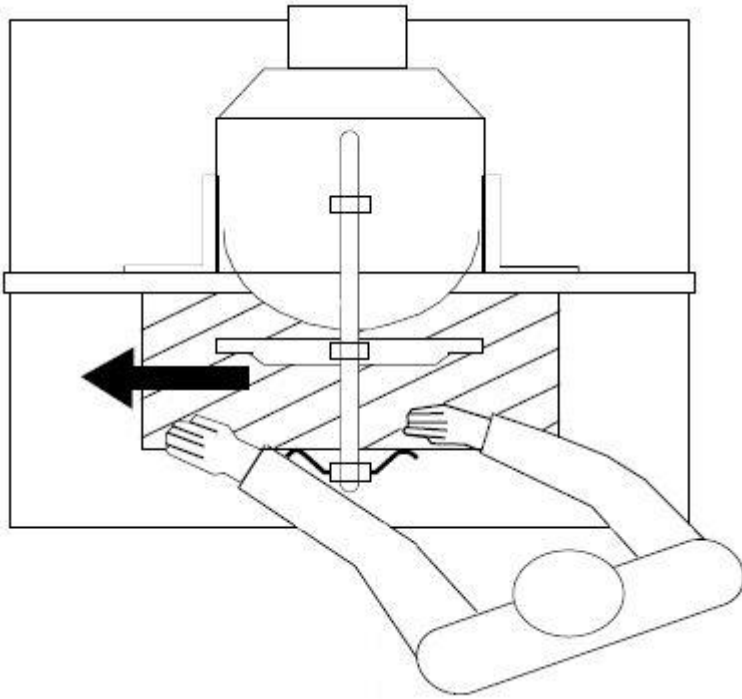

Feed the workpiece straight across the machine table, holding the fingers close together and guiding the workpiece with the palm of your hands. Never put your hands under or behind the cutter guard.

Always keep your hands well clear of the rotating cutter.

Always feed the workpiece against the cutter rotation: From right to left when viewed from the front of the machine.

Use a push stick when working the ends of a narrow workpiece.

Always machine the workpiece over its entire length.

Support long pieces with roller stands or table extensions.

Diagram shows regular feed direction with the selector switch in 'L' position.

Troubleshooting Guide

Problem	Cause	Remedy
Machine does not start	Tripped MCB	Reset Fuse
	Direction Switch not Set	Select 'L' or 'R'
	Faulty switch	Replace switch
Only starts when Green button is held down	Faulty switch	Replace switch
Machine does not run but buzzing noise heard from motor	Failed capacitor	Replace the motor start capacitor.
Spindle RPM Slows During Cut	Cut is too big	Re-set fence to make a smaller cut
Cuts are slow, wood is blackened	Cutters are blunt	Sharpen the cutters
Spindle tilt or blade height difficult to adjust	Adjusting rod obstructed by dust build up	clean and lubricate the mechanism
Spindle tilt or blade height will not adjust	Lock is engaged	Release the lock

Optional Accessory: W050ET Extension Table

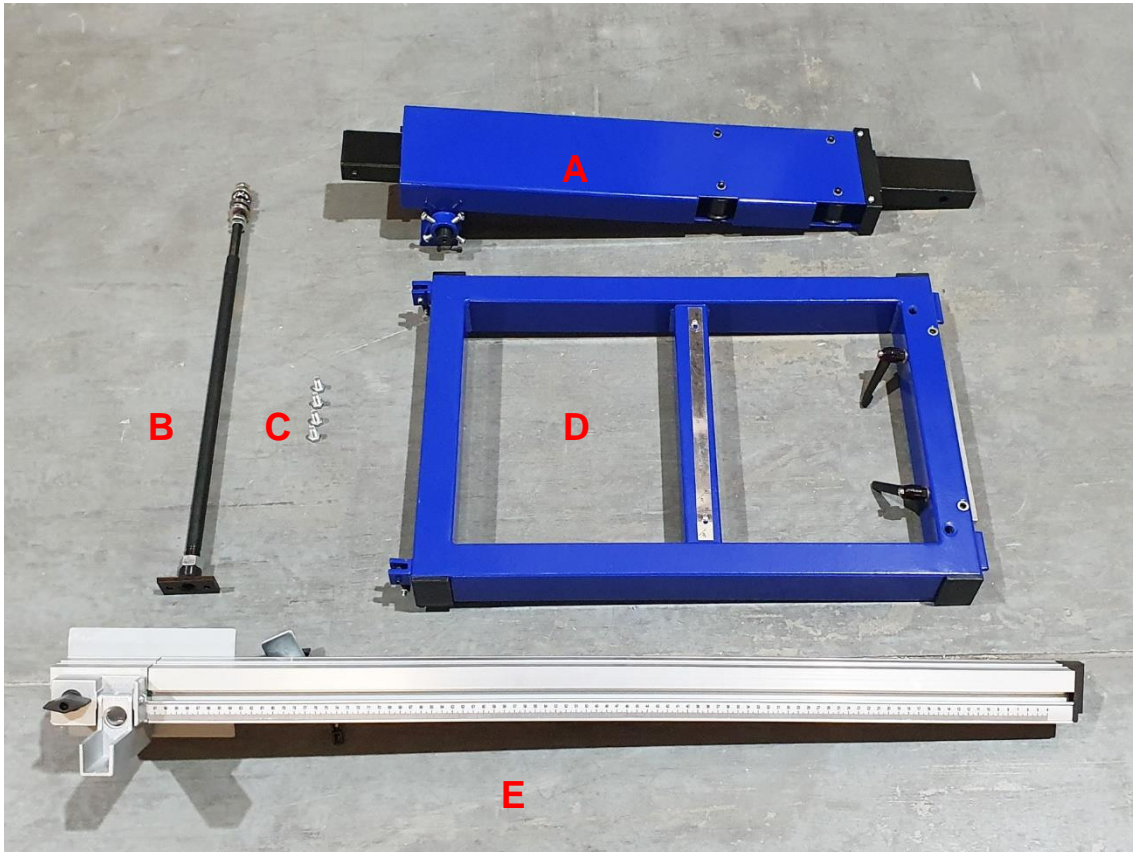

A) Telescopic Slide **B)** Table Support Rod **C)** Fixing Bolts **D)** Extension Table **E)** Guide Fence

Assembly

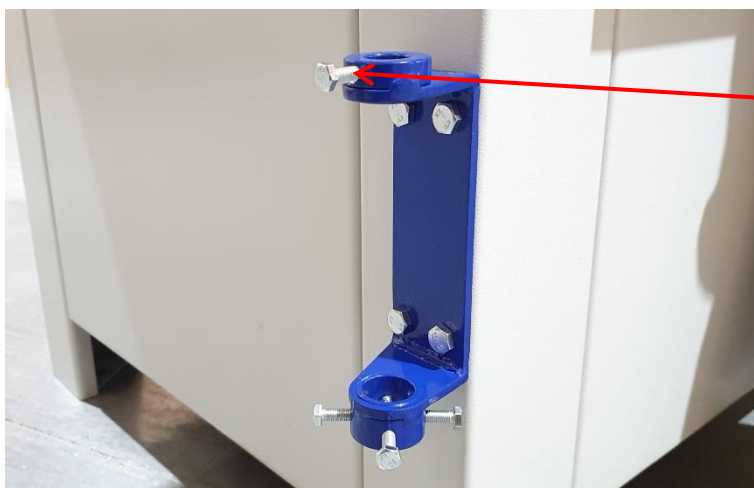

Fit The Telescopic Slide

Locking Bolt

Use a 10mm spanner to undo the locking bolt and then remove the pivot bar to separate the mounting bracket and the telescopic arm.

Mount the bracket onto the side of the machine using 4 hex head fixing bolts.

Tighten with a 13mm spanner.



Place the telescopic arm back into position inside the mounting bracket and insert the pivot bar.

With around 15mm projecting above the top of the bracket, lock the pivot bar in place with the locking screw.

Tighten the 4 lower screws set out at 90 degree intervals.

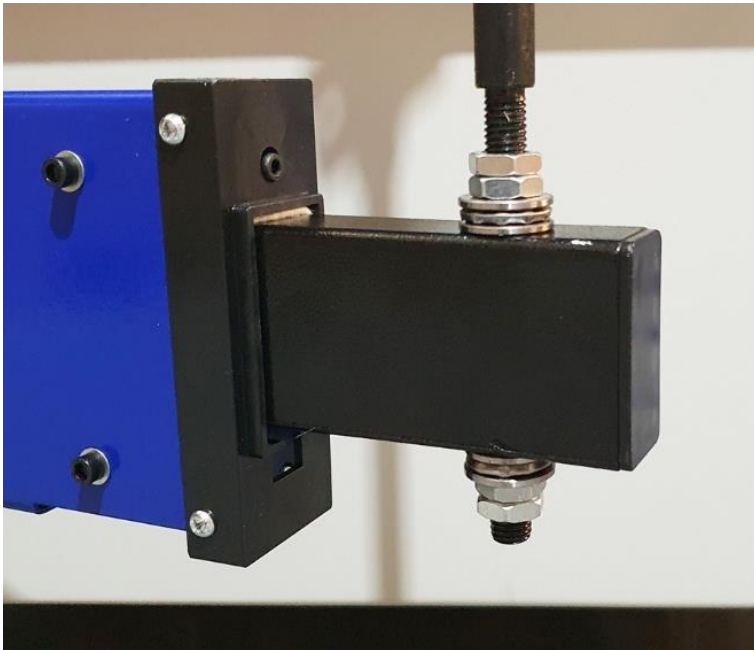

Fit The Table Support Rod

From the threaded end of the Support Rod, remove 2 Nuts and 3 washers.

Insert the Rod into the hole in the end of the telescopic arm and refit the washers and nuts.

Use 2 x 17mm spanners to lock the upper nuts against each other. Then tighten the lower nuts.

You may need to adjust this again later to set the height of the Support Arm when levelling the extension table.

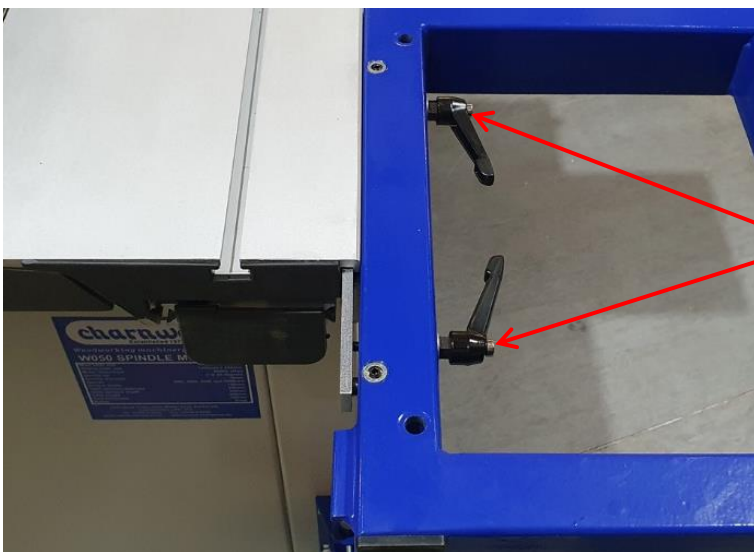

Fit The Extension Table

Use a 5mm Allen key to remove 2 bolts from the underside of the extension table.

Loosen the 2 ratchet handles to allow the locating bar to feed into the end of the sliding carriage extrusion.

Take care to support the other end of the table until it lines up with the end of the extrusion, then move the table Support Rod into a position to support the table.

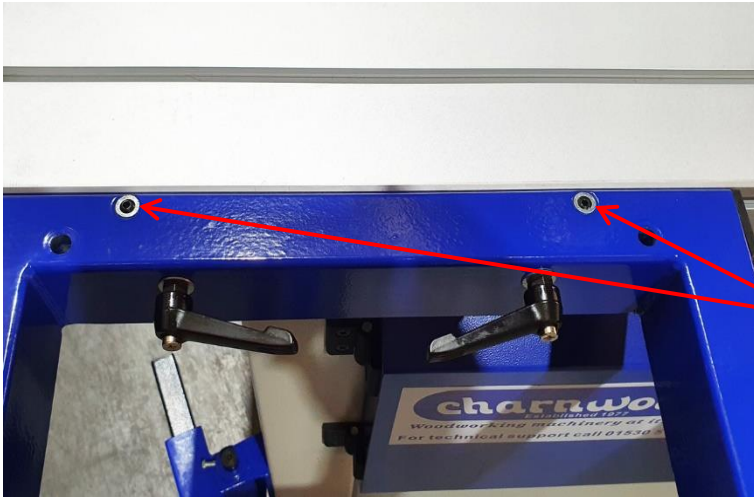

Adjust The Table

Use a straight edge to check the top of the Extension Table is Level with the top of the Sliding Carriage.

Lock the 2 ratchet handles.

Use a 3mm Allen Key to tighten 2 height setting screws. These keep the table height when it is adjusted in future.

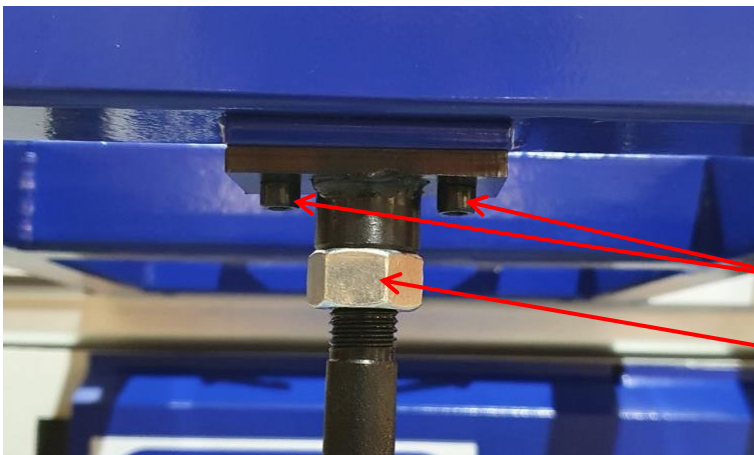

Using a long straight edge, check the floating end of the table is level to the Sliding Carriage table.

If not, rotate the bracket on the top of the Table Support Rod to the correct level.

Re-fit the 2 bolts.

Use a 17mm spanner to raise the locking nut.

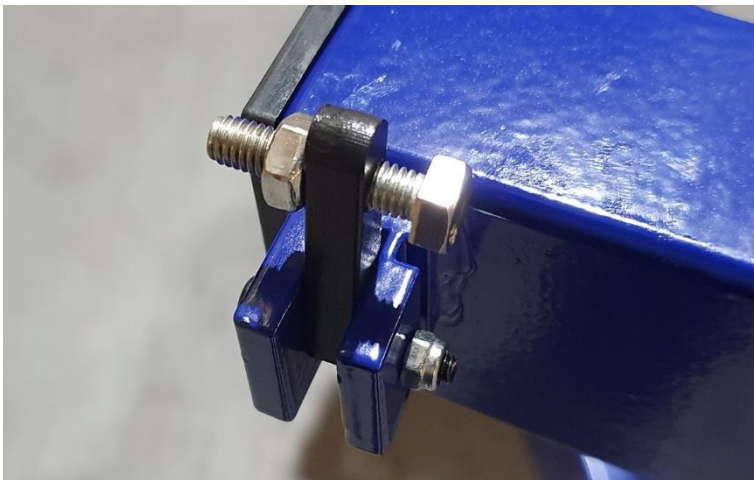

Fit The Fence

Flip up the 90 degrees stop.

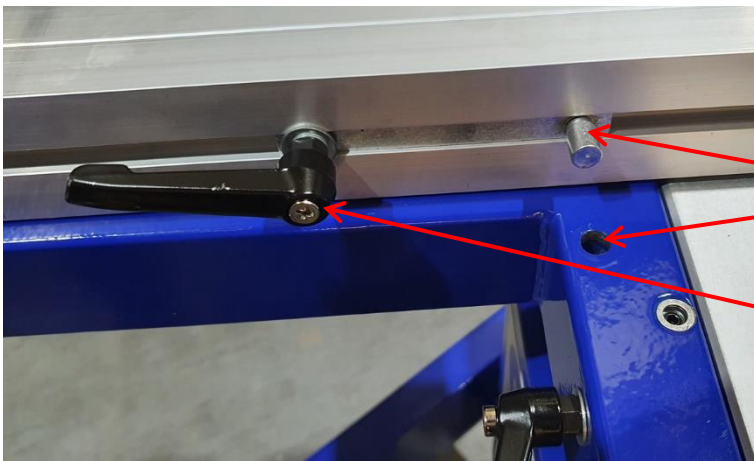

Place the fence onto the table with the locating pin in the matching hole in the extension table.

Locating Pin
Locating Hole

Lock the ratchet handle

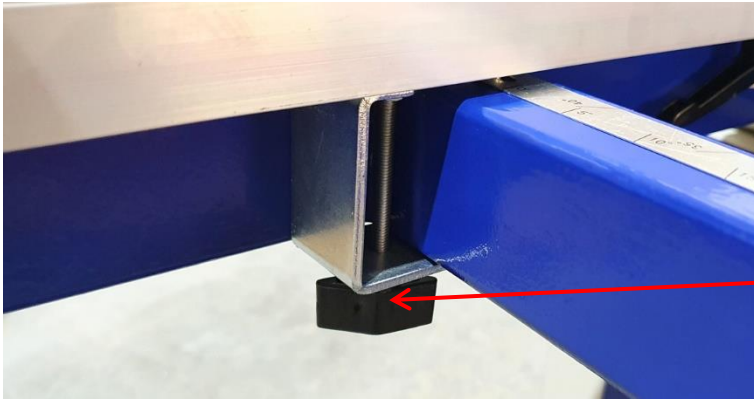

Rotate the fence until it sits back against the 90 degrees stop.

Move the U bracket so it sits underneath the cross member of the extension table.

Lock the fence in place by tightening the locking knob.

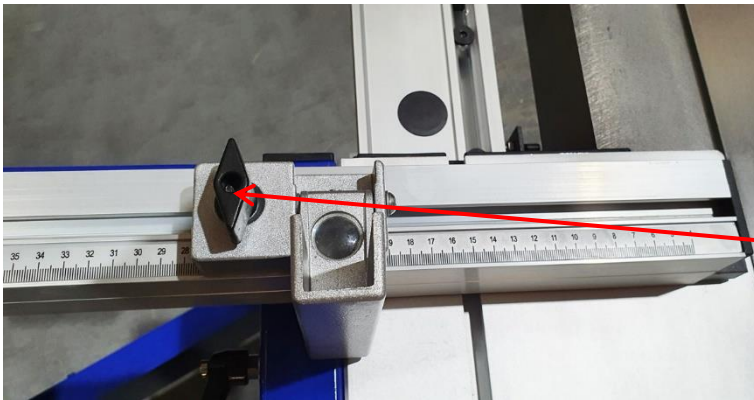

The fence is equipped with a Flip Over Sliding Stop

The position can be read off the scale and fixed with the locking knob.

Locking Knob

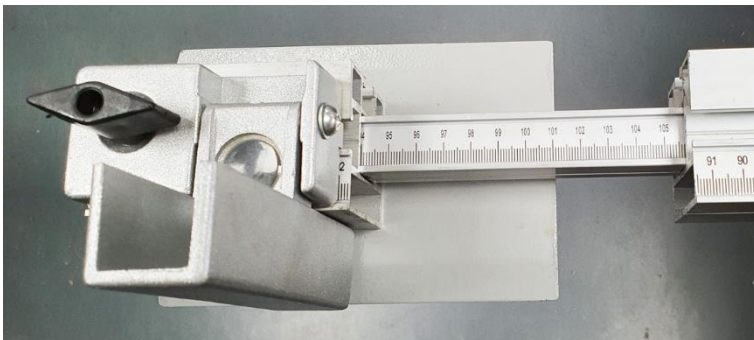

The fence is equipped with an extendable section to measure longer lengths or large panels.

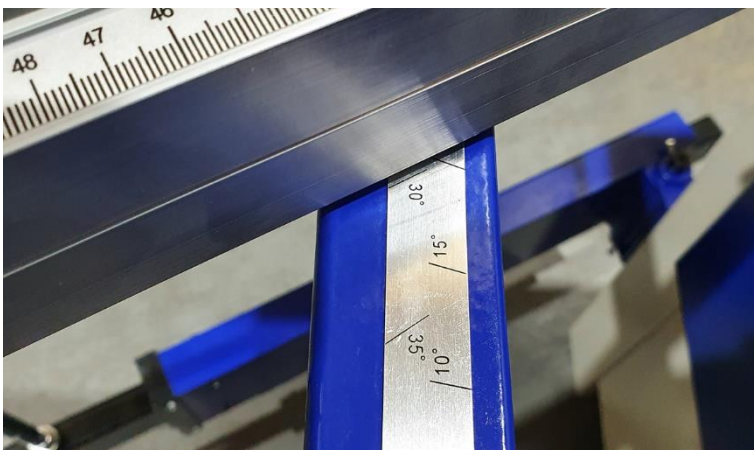

Fence Angle

The angle of the fence can be read from the scale.

The scale is adjustable and needs to be checked and set once assembly is complete.

Use a screwdriver to fix the position of the scale.

Please Note: The extension table can be assembled in reverse, with the fence on the opposite side of the table. When working in that manner the workpiece passes the cutters before the fence.

Declaration of Conformity

Charnwood Declare that Woodworking Vertical Spindle Moulder, Models W050 & W050P

Conforms with the following EU Directives: Machinery Directive 2006/42/EC
EMC Directive 2014/30/EU

Conforms with the following UK Regulations: Supply of Machinery (Safety) Regulations 2008
Electrical Equipment (Safety) Regulations 2016

And further conforms to the machinery example for which the type examination Certificate No. BM50496437 and AE50390657, have been issued by TUV Rheinland LGA Products GmbH, Tillystrasse 2, 90431, Nurnberg.

I hereby declare that equipment named above has been tested and found to comply with the relevant sections of the above referenced specifications. The machinery complies with all essential requirements of the directives and regulations.

Signed: 

Dated: 01/10/2022

Location: Leicestershire

Richard Cook, Director



Please dispose of packaging for the product in a responsible manner. It is suitable for recycling. Help to protect the environment, take the packaging to the local amenity tip and place into the appropriate recycling bin.

Only for EU countries



Do not dispose of electric tools together with household waste material!
In observance of European Directive 2002/96/EC on waste electrical and electronic equipment (WEEE) and its implementation in accordance with national law, electric tools that have reached the end of their life must be collected separately and returned to an environmentally compatible recycling facility.

Your local refuse amenity will have a separate collection area for WEEE goods.

W050 Wiring Diagram

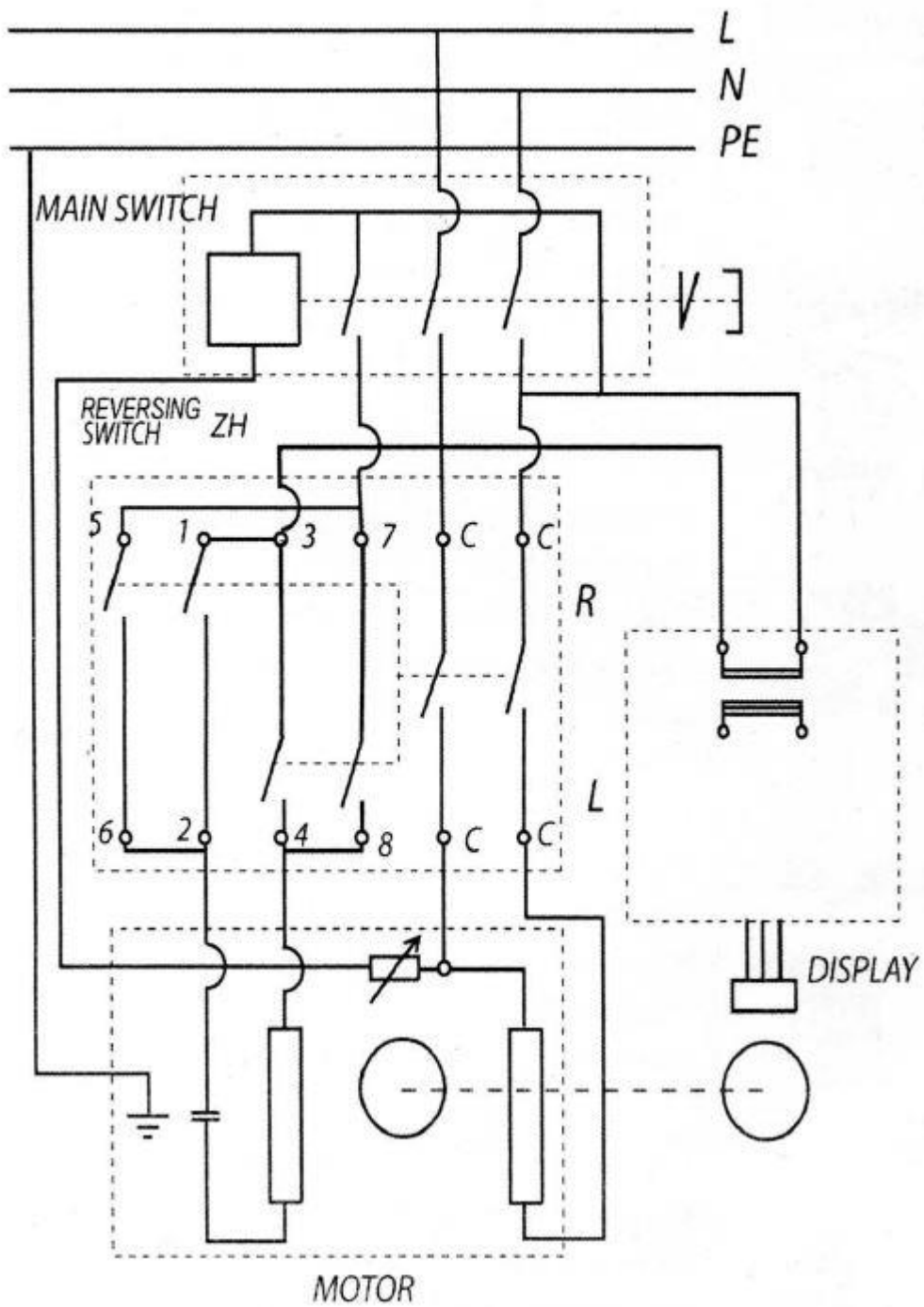

Parts List A

Part No.	Description	Part No.	Description
A01	Cutter Guard Assembly	A17	Swing arm (Optional Item)
A02	Table	A18	Lock nut M16 (Optional Item)
A03	Allen bolt M10x70	A19	Sliding bench (Optional Item)
A04	Mill drive set	A20	Guide Rail (Optional Item)
A05	Lock nut M10	A21	Sliding rail
A06	Flat washer 10mm	A22	Workpiece Clamp
A07	Label	A23	Allen bolt M12x65
A08	Work Stand	A24	Carriage bolt M8x45
A09	Spindle height display	A25	Lock nut M8
A10	On/Off Switch	A26	Guide bolt
A11	Door Sensor Switch QKS8	A27	Allen M8x16
A12	Pan head screw M4x30	A28	Lock nut M12
A13	Left Panel	A29	End stop guide
A14	Star type screw M8x15	A30	Hex head screw M5x16
A15	Lock nut M12 (Optional Item)	A31	Hex head screw M6x50
A16	Thrust Bearing 8101 (Optional Item)	A32	Lock nut M6

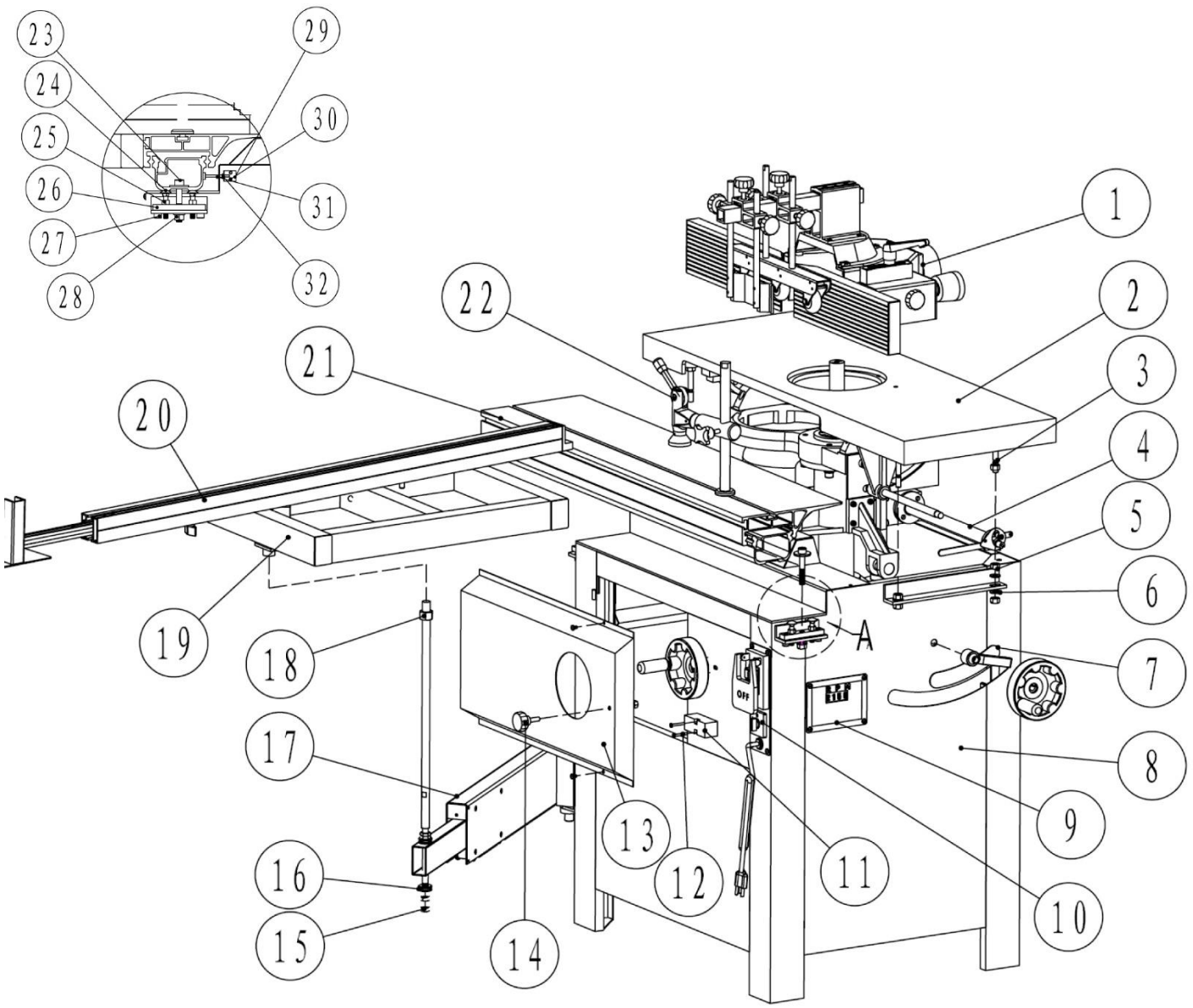

Parts List C

Part No.	Description	Part No.	Description
C01	Tilt Rod	C22	Tilt Arbor Bracket
C02	Trunion Guide	C23	Elevator
C03	Spindle Bracket	C24	Allen Bolt M8 x 20
C04	Trunion	C25	Allen Bolt M10 x 16
C05	Locking Seat	C26	Washer 10mm
C06	Allen Bolt M10 x 35	C27	Allen Bolt M12 x 30
C07	Allen Bolt M8 x 16	C28	Allen Bolt M8 x 20
C08	Washer 12mm	C29	Hex head screw M8 x 16
C09	Locking shaft	C30	Spindle Pulley
C10	Tilt Locking Lever	C31	Flat Key 8 x 8 x 25
C14	Tilt Locking Block	C32	V-Belt
C15	Locking Plate	C33	Allen bolt M10 x 45
C16	Spindle Shaft	C34	See G19
C17	Spindle Housing	C35	Allen Bolt M10 x 16
C18	Allen bolt M10 x 35	C36	End Stop
C19	Spring Washer M10	C37	Allen Bolt M10 x 45
C20	Washer M10	C38	Tilt Rod Nut
C21	Allen Bolt M6 x 20	C39	Tilt Rod End Stop Nut

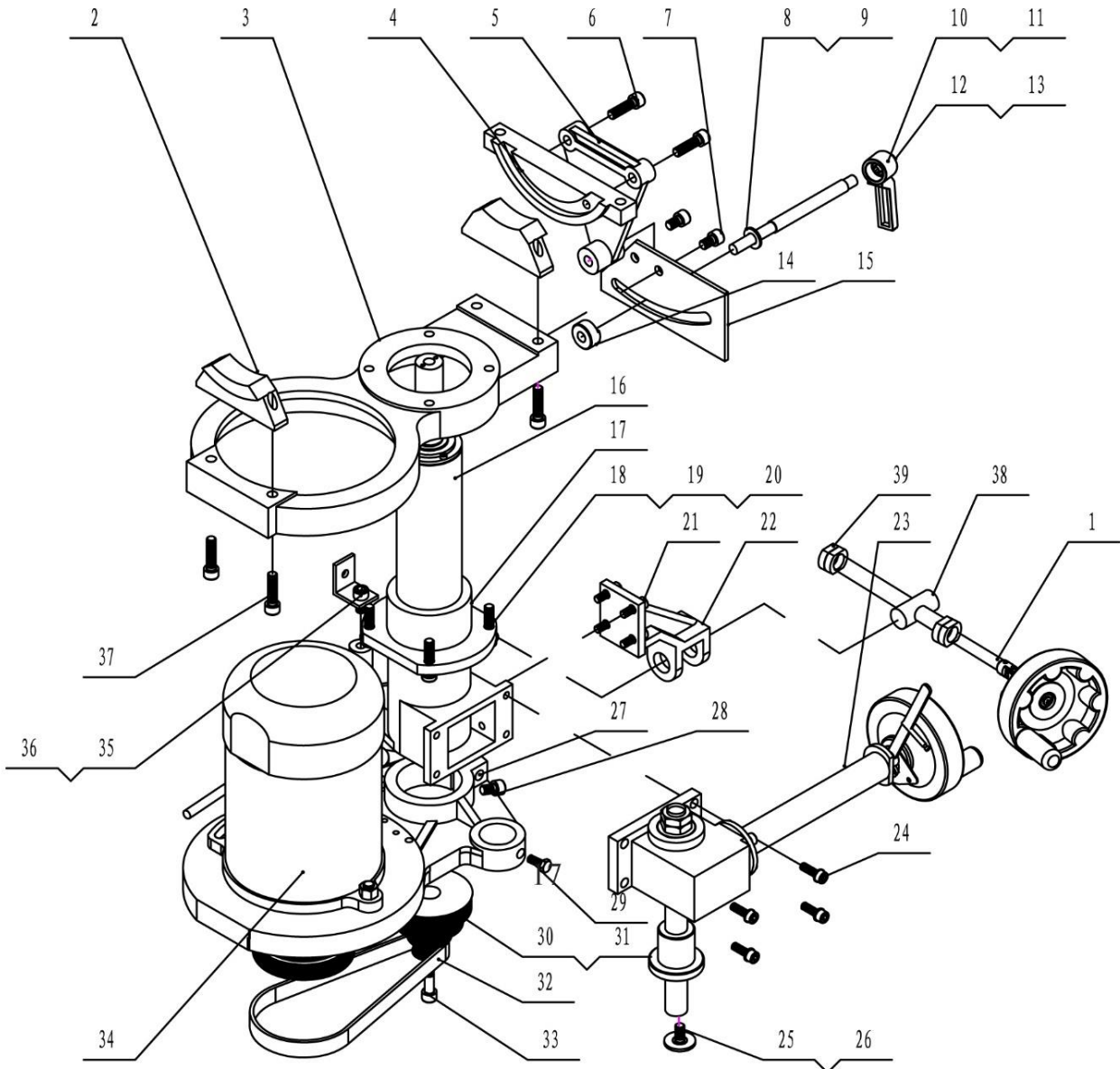

Parts List D

Part No.	Description
D01	Countersunk Screw M5 x 12
D02	Washer M6
D03	Hand Wheel
D04	Washer M12
D05	Locking Lever Plate
D06	Allen Bolt M6 x 25
D07	Bushing
D08	Locking Lever
D09	Rise Shaft
D10	Rise Shaft Housing
D11	Allen Bolt M8 x 25
D12	Spring Washer M8
D13	Bearing 80202
D14	Worm Drive Bushing
D15	Worm Drive
D16	Worm Drive Housing
D17	Helical Gear
D18	Spindle Bushing
D19	Thrust Bearing 8105
D20	Special Washer
D21	Thin Hex Nut M20
D22	Rising Spindle

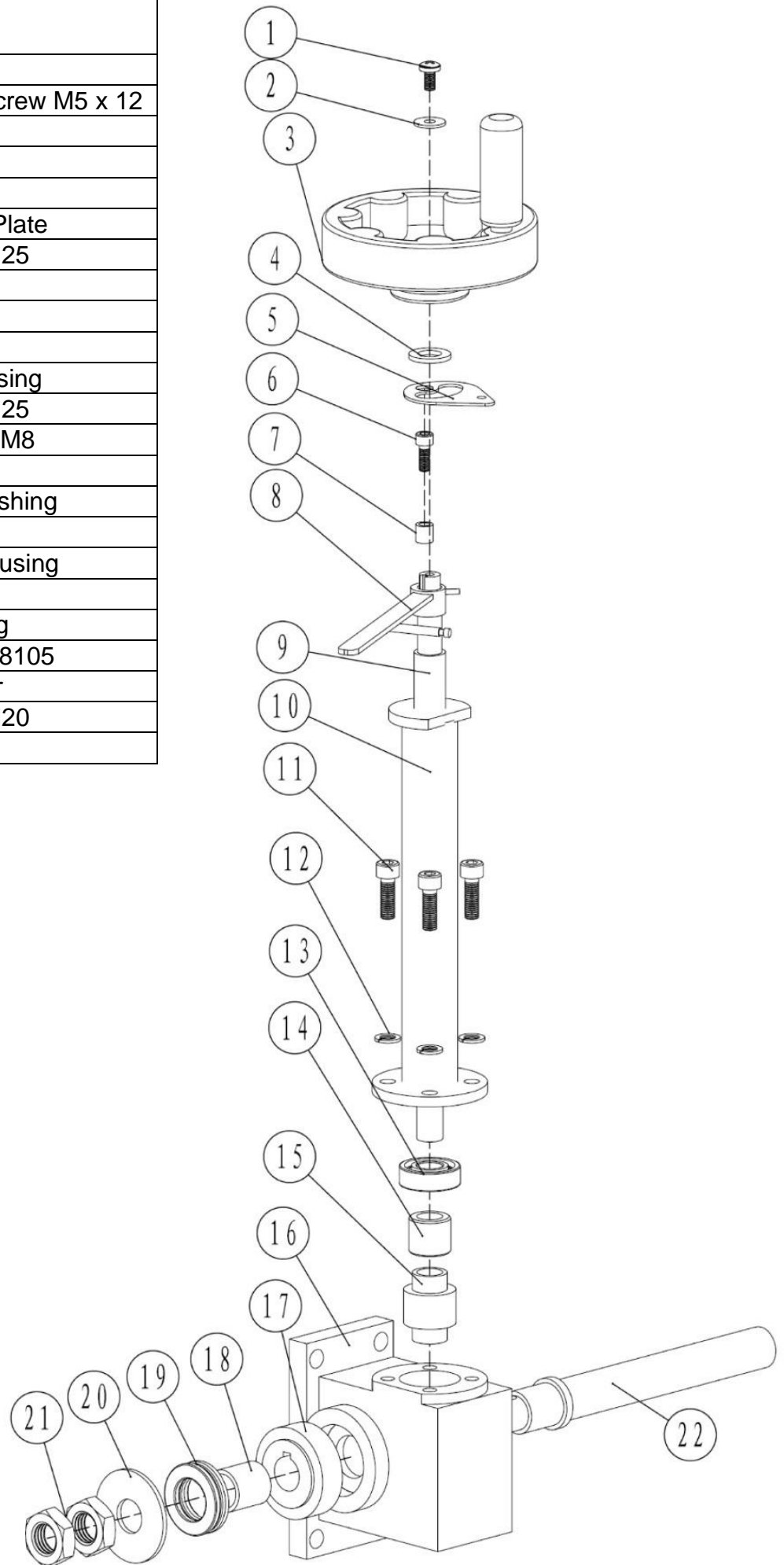

Parts List E

Part No.	Description	Part No.	Description
E01	Allen Bolt M12 x 25	E08	Spindle Guide Tube
E02	Lock Flange	E09	Spindle Shaft B
E03	Spindle Shaft A	E10	Spindle Guide Tube
E04	Pan Head Screw M5 x 10	E11	Bearing 80106
E05	Lock Nut A	E12	Lock Nut M30
E06	Lock Nut B	E13	Lock Nut M30
E07	Allen Bolt M5 x 16		

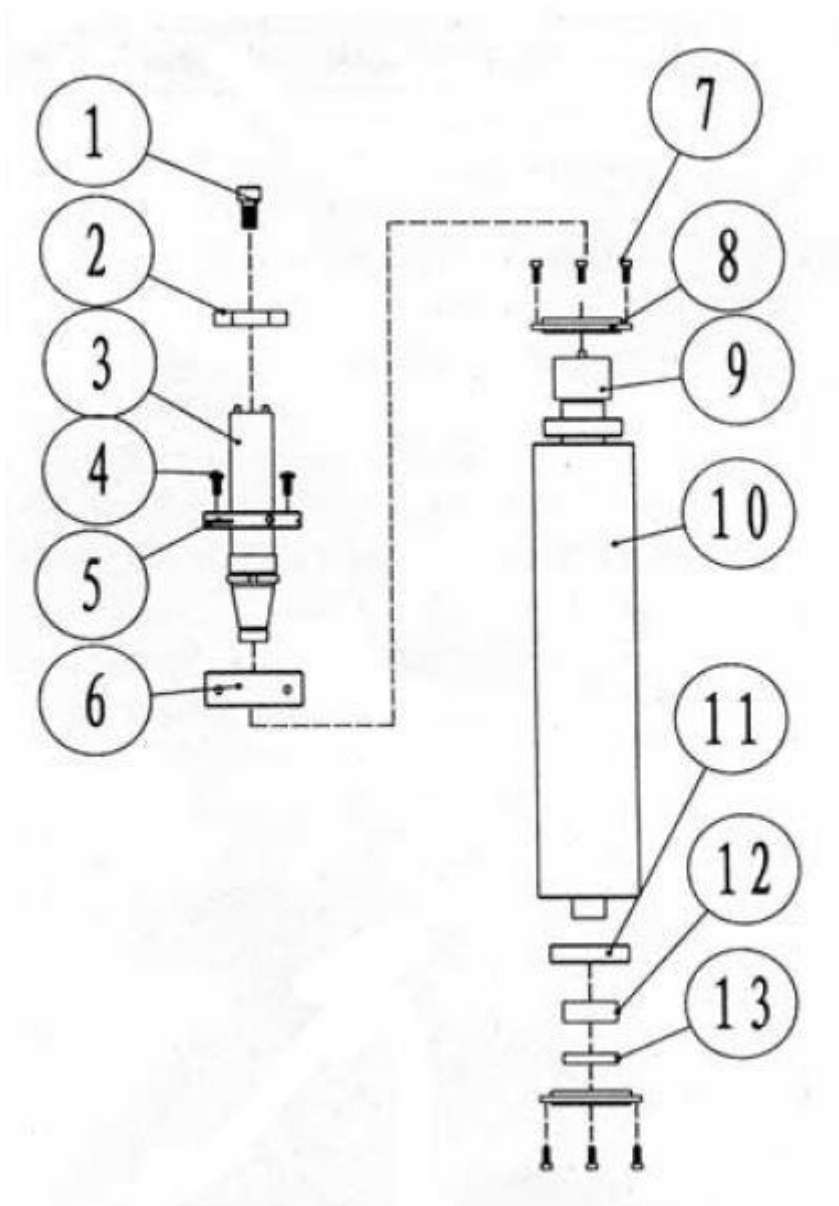

Parts List F

Part No.	Description	Part No.	Description
F01	Countersunk Screw M5 x 12	F07	Circlip 19mm
F02	Washer 6mm	F08	Bearing Housing
F03	Hand Wheel	F09	Bushing
F04	Circlip 9mm	F10	Roll Pin 3 x 16
F05	Shaft	F11	Gimbal
F06	Bearing 6198	F12	Threaded Rod

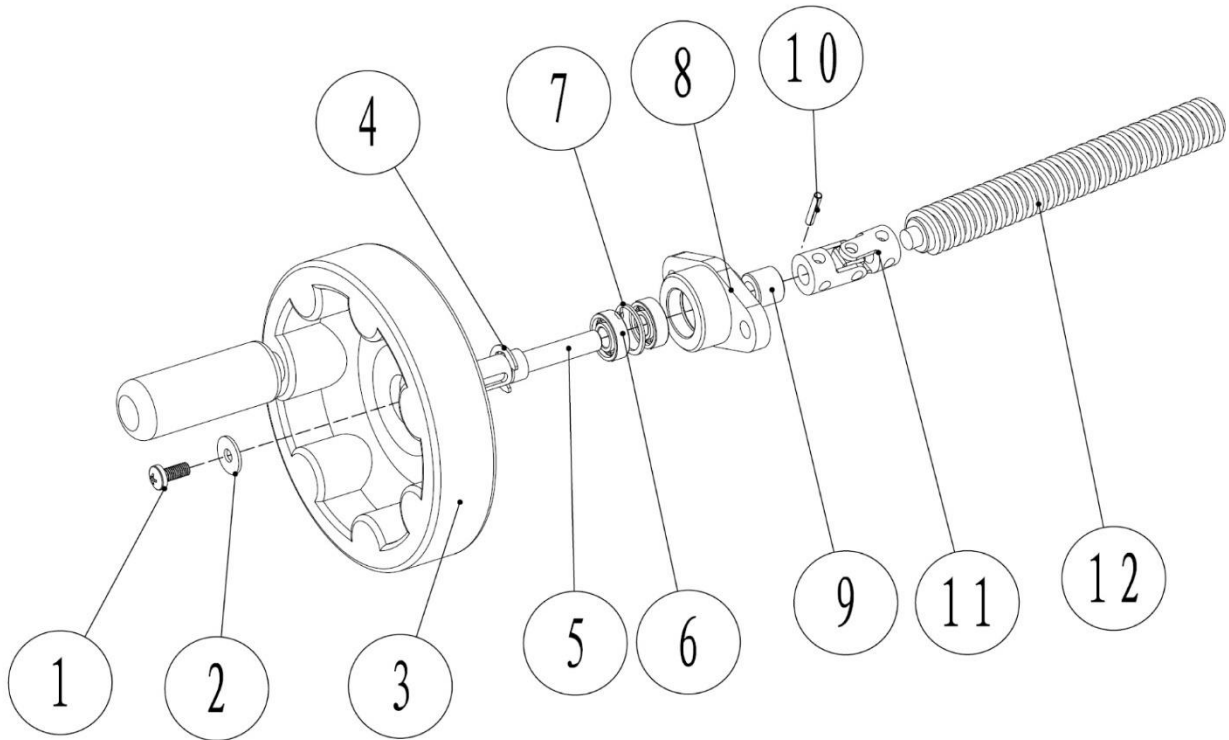

Parts List G

Part No.	Description	Part No.	Description
G01	Allen Bolt M10 x 15	G11	Lock Nut M10
G02	Washer 10mm	G12	Tension Lever
G03	Guide Bar	G13	Circlip 24mm
G04	Tension Joint	G14	Motor Pulley
G05	Washer 16mm	G15	Washer 10mm
G06	Hex Nut M16	G16	Allen Bolt M10 x 20
G07	Thread Joint	G17	Hex Head Screw M12 x 40
G08	Lock nut M10	G18	Motor Mount
G09	Motor Tension Joint	G19	Motor
G10	Thread Tension	G20	Hex Nut M12

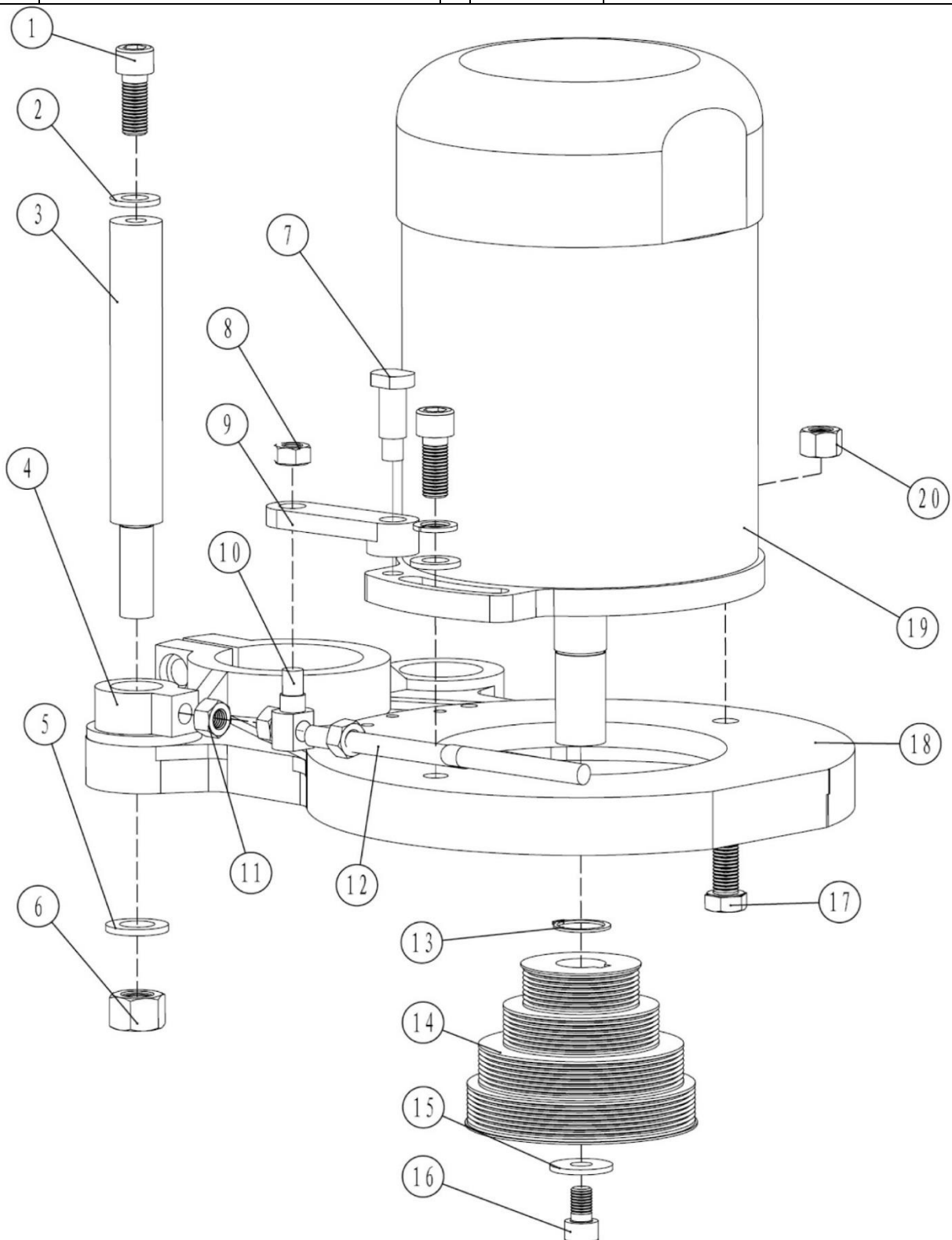

Parts List H

Part No.	Description
H01	Pan Head Screw M4 x 12
H02	On/Off Switch KJD17B-16
H03	Switch Batten
H04	Switch ZH-HC-3
H05	Nut M20
H06	Cable

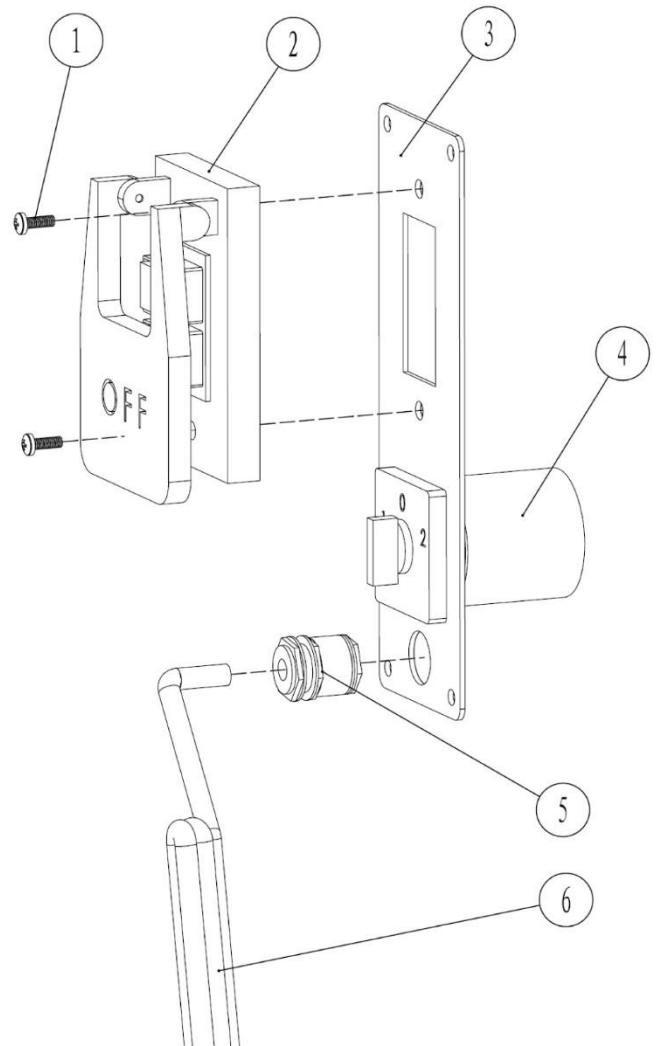

Parts List I (Optional Items)

Part No.	Description	Part No.	Description
I01	Guide Bar	I11	Pan Head Screw M5 x 12
I02	End Cap	I12	End Cap
I03	Telescopic Arm	I13	Allen Bolt M6 x 12
I04	Allen Bolt M6 x 12	I14	Washer 6mm
I05	Circlip 24mm	I15	Guide Bolt A
I06	Bearing 61901	I16	Guide Bolt B
I07	Shaft	I17	Guide Bolt C
I08	Wheel	I18	Swing Arm
I09		I19	Guide Bar
I10	Allen Bolt M6 x 12	I20	Allen Bolt M6 x 12

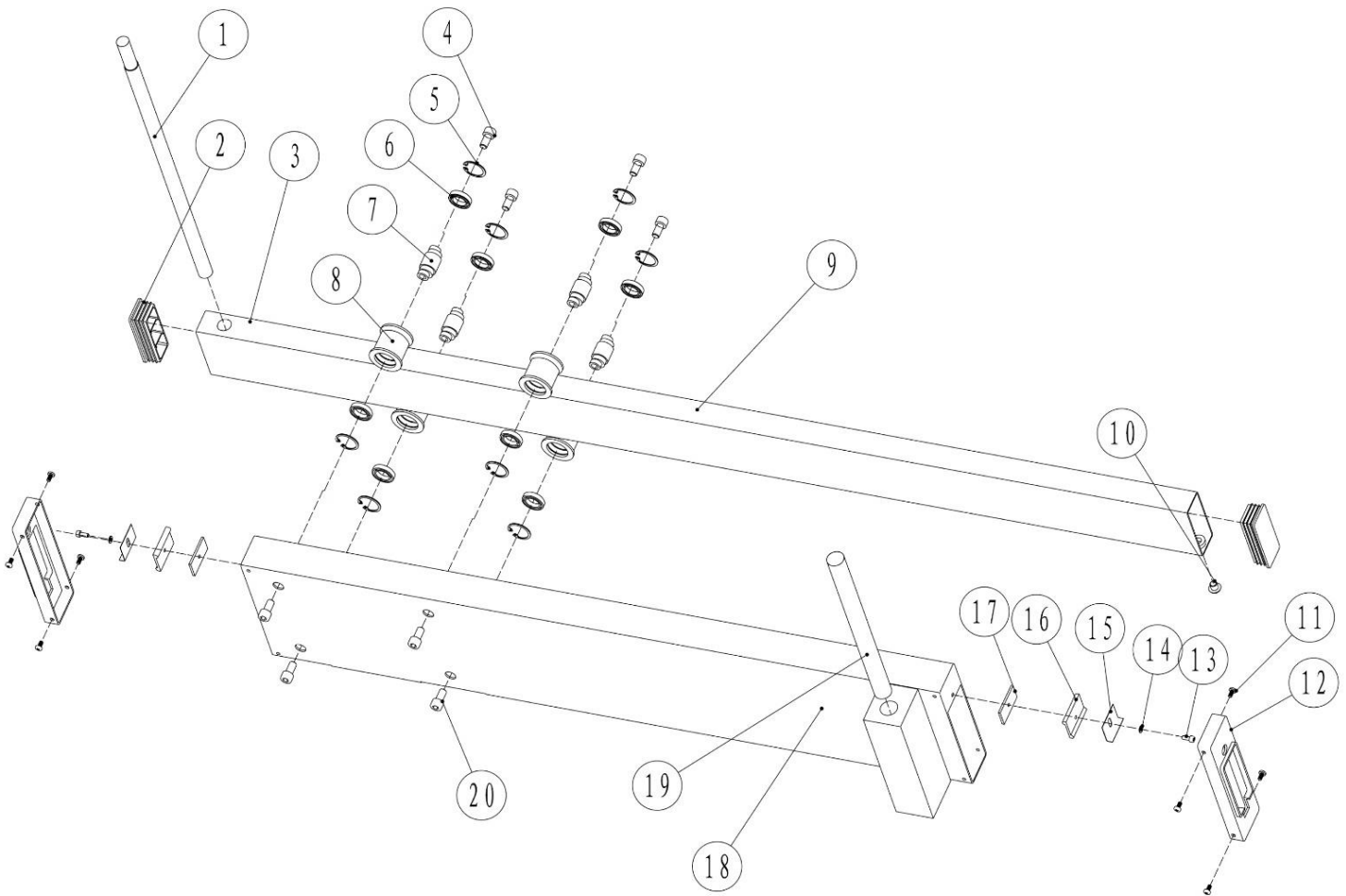

The Telescopic Arm is supplied with the optional W050ET Extension Table

Parts List J (Optional Items)

Part No.	Description	Part No.	Description
J01	End cap	J13	Base Plate
J02	Guide Rail	J14	Countersunk Screw M6 x 30
J03	Scale A	J15	Sliding Block
J04	Stop Rail	J16	Spring Washer 6mm
J05	Seat A	J17	Handle
J06	Scale Reader Lens	J18	Sliding Block
J07	Handle	J19	Seat C
J08	Spring Washer 6mm	J20	Handle
J09	Seat B	J21	Sliding Block
J10	Scale B	J22	Spring Washer 6mm
J11	Block	J23	Ratchet Lever M6
J12	End Stop	J24	Roll

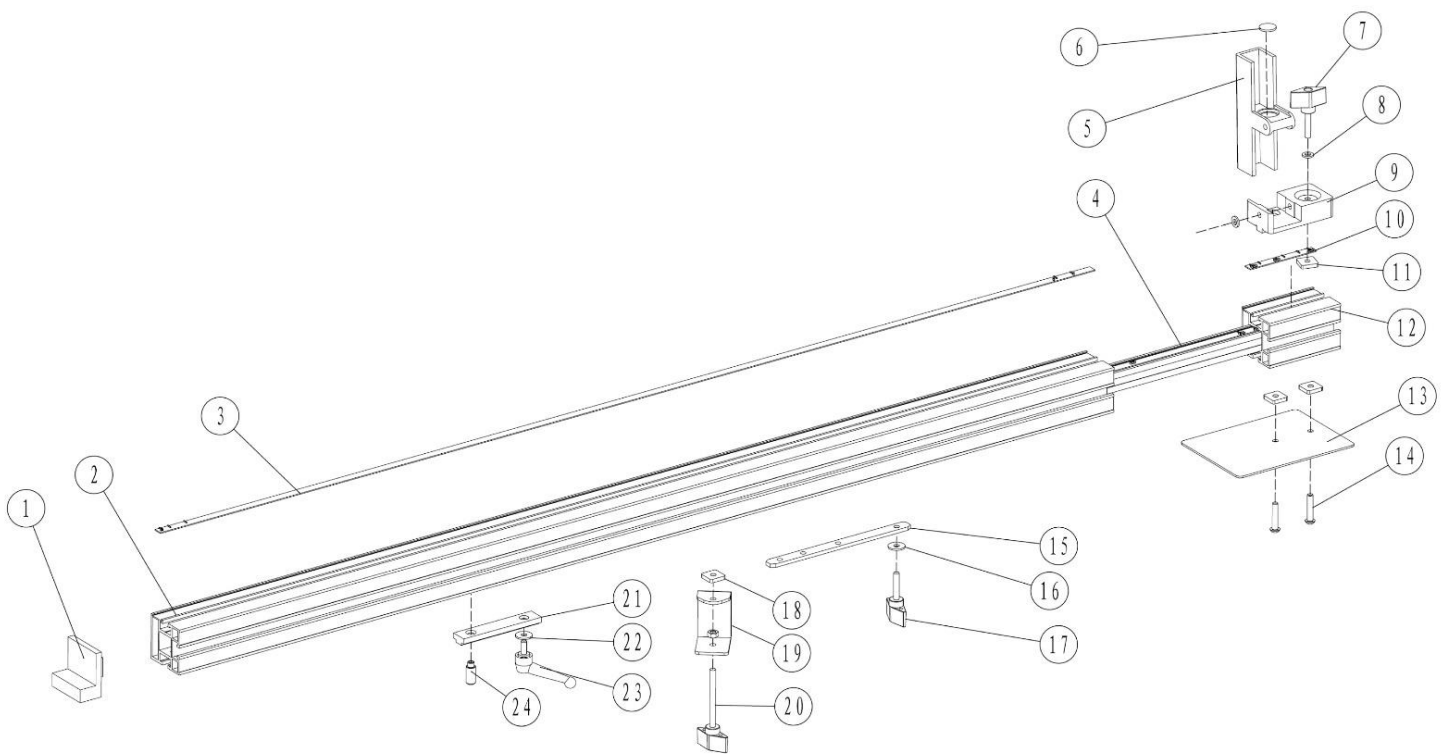

The Fence is supplied with the optional W050ET Extension Table

Parts List K

Part No.	Description	Part No.	Description
K01	Sliding Bench	K03	Spring Washer 6mm
K02	Tilt lock	K04	Guide Plate

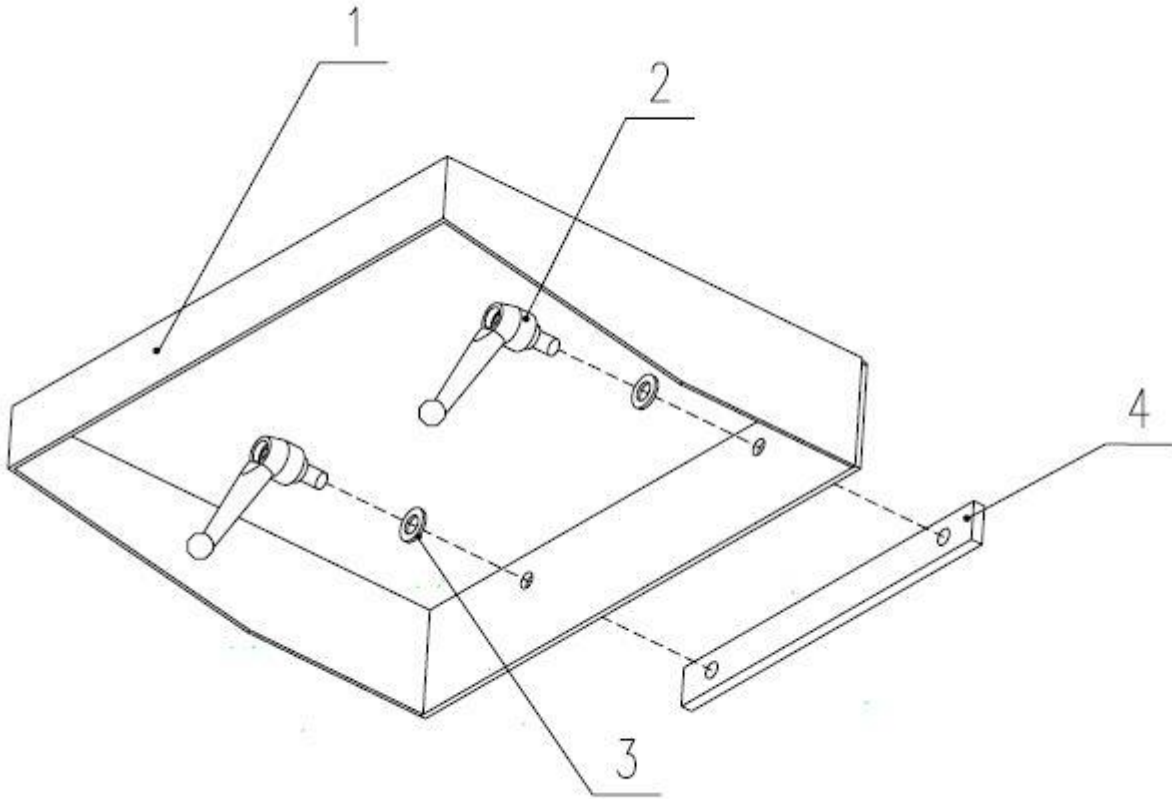

Parts List L

Part No.	Description	Part No.	Description
L01	Table Ring 200mm Tilt	L03	Table Ring 150/110mm
L02	Table Ring 110/80mm	L04	Table Ring 200/150mm

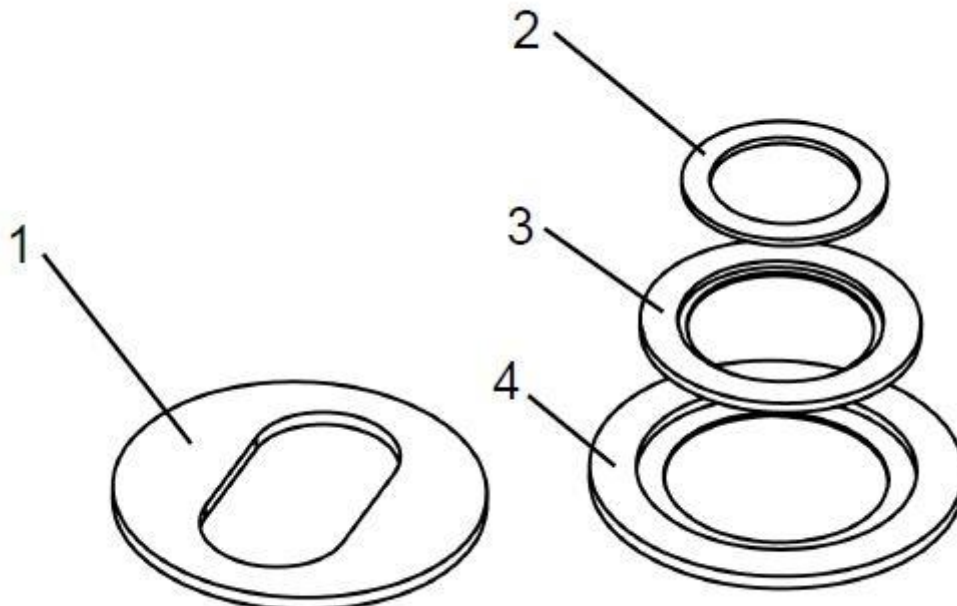

Parts List M

Part No.	Description	Part No.	Description
M01	Spindle shaft	M06	Allen Bolt M12 x 25mm
M02	Spindle ring 50x30x30mm	M07	Allen Key 10mm
M03	Spindle ring 50x30x10mm	M08	Spindle ring 50x30x20mm
M04	Cutter Block (Not Included)	M09	Spindle ring 50x30x10mm
M05	Lock flange	M10	Spindle ring 50x30x5mm

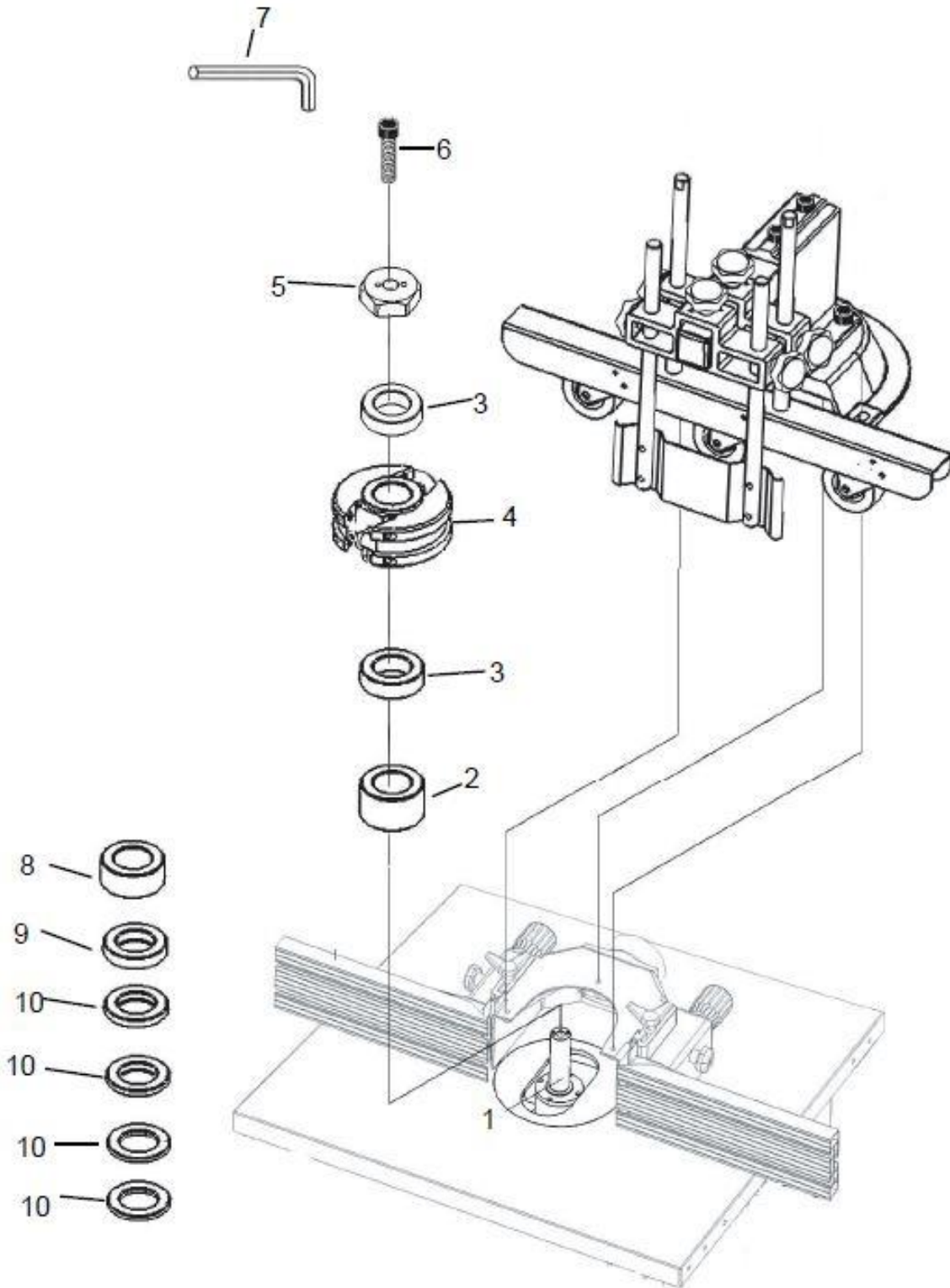



Woodworking machinery at its best!

Updated October 2022

**Charnwood, Cedar Court, Walker Road,
Hilltop Industrial Estate, Bardon Hill, Leicestershire, LE67 1TU**

Tel. 01530 516 926
email: sales@charnwood.net website: www.charnwood.net