



Woodworking machinery at its best!

**ROUTER TABLE
OWNERS MANUAL**

MODEL: W014



Charnwood, Cedar Court, Walker Road, Bardon, Leicestershire, LE67 1TU
Tel. 01530 516 926 Fax. 01530 516 929 email: sales@charnwood.net

www.charnwood.net

GENERAL SAFETY RULES



WARNING: Do not attempt to operate the machine until you have read thoroughly and understood completely all instructions, rules, etc. contained in this manual. Failure to comply may result in accidents involving fire, electric shock, or serious personal injury. Keep this owner's manual and review frequently for continuous safe operation.

1. Know your machine. For your own safety, read the owner's manual carefully. Learn its application and limitations, as well as specific potential hazards pertinent to this machine.
2. Make sure all tools are properly earthed.
3. Keep guards in place and in working order. If a guard must be removed for maintenance or cleaning, make sure it is properly replaced before using the machine again.
4. Remove adjusting keys and spanners. Form a habit of checking to see that the keys and adjusting spanners are removed from the machine before switched it on.
5. Keep your work area clean. Cluttered areas and workbenches increase the chance of an accident.'
6. Do not use in dangerous environments. Do not use power tools in damp or wet locations, or expose them to rain. Keep work areas well illuminated.
7. Keep children away. All visitors should be kept a safe distance from the work area.
8. Make workshop childproof. Use padlocks, master switches and remove starter keys.
9. Do not force the machine. It will do the job better and be safer at the rate for which it is designed.
10. Use the right tools. Do not force the machine or attachments to do a job for which they are not designed. Contact the manufacturer or distributor if there is any question about the machine's suitability for a particular job.
11. Wear proper apparel. Avoid loose clothing, gloves, ties, rings, bracelets, and jewellery which could get caught in moving parts. Non-slip footwear is recommended. Wear protective hair covering to contain long hair.

12. Always use safety glasses. Normal spectacles only have impact resistant lenses. They are not safety glasses.
13. Do not over-reach. Keep proper footing and balance at all times.
14. Maintain machine in good condition. Keep machine clean for best and safest performance. Follow instructions for lubrication and changing accessories.
15. Disconnect the machine from power source before servicing and when changing accessories or (if using a fixed base router) when mounting or remounting the motor.
16. To avoid accidental starting, make sure the switch is in the OFF position before plugging in the mains cable.
17. Never leave the machine running unattended. Turn the power off. Do not leave the machine until it comes to a complete stop.
18. Do not use any power tools while under the effects of drugs, alcohol or medication.
19. Always wear a face or dust mask if operation creates a lot of dust and/or chips. Always operate the tool in a well ventilated area and provide for proper dust removal. Use a suitable dust extractor.

ADDITIONAL RULES FOR ROUTER TABLES

1. Always hold the work piece against the fence.
2. Never perform any "free hand" operation. Do not use only your hands to support or guide the work piece. Always use featherboards to help secure the work piece when cutting smaller pieces.
3. Feed the work piece to the router bit against the rotating direction. Feed direction will normally be from right to left.
4. Never draw the workpiece back during cutting. Wait until the router bit stops before drawing back the workpiece.
5. Make sure the portable router has been installed securely before starting the machine.
6. Make sure the router bit is locked securely before operating.

Specification

Table surface	800 x 600mm
Table apertures	97mm 66mm 32mm
Table height	870mm
Dust hood outlet diameter	68mm
Net weight	24kg
Rating	Light trade

Features

Can be used with any portable $\frac{1}{4}$ " or $\frac{1}{2}$ " router

Large aperture for easy router mounting and removal

Large, smooth table

Mounting plate magnetically secured, allowing tool free removal from the table

Generously sized fence incorporating mounting slot for featherborards

Two insert rings supplied to match aperture to cutter size

Large mitre fence with presets for 90° and 45° angles

Two large, easy to read scales built into the table top

Unpacking the Router Table



All parts are packed in one carton.

Unpack the parts carefully and check that everything is present, using the parts list on pages 10, 11 and 12. If anything is missing contact the retailer immediately.



Assembling the Floor Stand

Important: All nuts and bolts should only be fastened finger tight until assembly is complete.

Lift out the router mounting plate and invert the table top. Place the inverted table on a suitable bench and ensure that the T-slot which runs from one side of the table to the other is at the front.

Take two blue rails 560mm and bolt them to the underside of the table as shown, using hex headed bolts and washers.

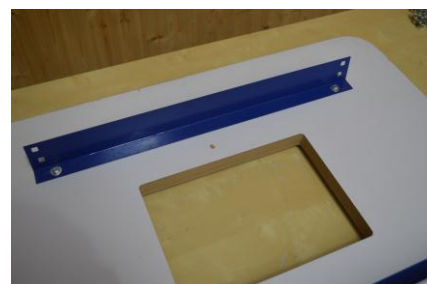

Bolt each leg on, in turn and then add the two blue rails, 360mm using coach bolts, washers and nuts.

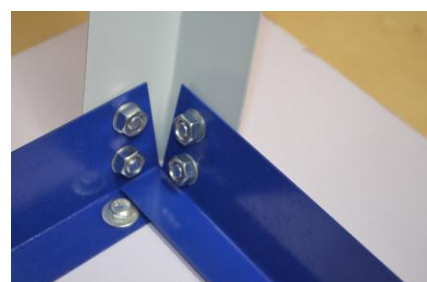

Bolt on the four remaining blue cross braces, ensuring that the one bearing the Charnwood logo and the model number of your router table is at the front. We are proud of our products and you will need the model number should you wish to order accessories.



Fit the four rubber feet to the legs.

Stand the router table on its feet, true it up and tighten all the nuts and bolts.

Assembling the Fence and Cutter Guard

Take two of the black, castellated knobs, remove the bolts from them and insert one in each of the T-slots running front to back on the table. Take the anodised aluminium angle and fit it over the bolts. The vertical face should be to the front. Place one washer and black knob on each bolt.



Slide the heads of two hex head bolts into the channel of one part of the fence and fit them through the two holes in one side of the aluminium angle. Secure with two black, castellated knobs. Do the same for the other part of the fence.



Fit the dust extractor port as shown, with the two long setscrews provided.

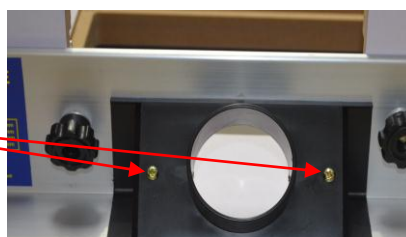

Take the two bolts that are fitted with tri-wing Knob and slide each bolt head into the channel in the front of the fence. Fit the cutter guard slots over the bolts and tighten the tri-wing knobs. By loosening these knobs and sliding the guard up or down, different sizes of cutter and work piece can be accommodated. When operating, slide the fence halves in or out to support the work piece as close to the cutter as is practical.



Assembling and Fitting the Mitre Fence

Using the Allen key provided, loosen the grub screw in the mitre fence and lower the pivot pin approximately 6mm. Tighten it in this position.

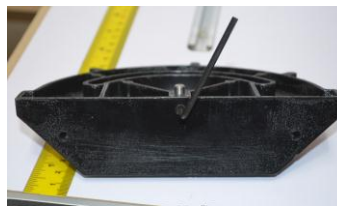

Slide the black metal bar into the T-slot across the front of the table. Place the pivot pin in the front hole and screw the locking handle through the curved slot into the threaded hole.

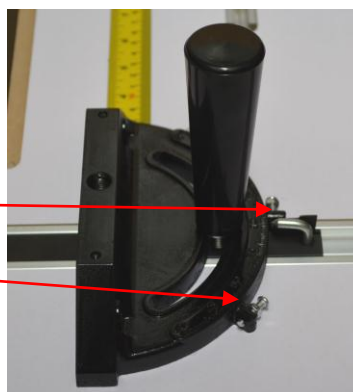

There are adjustable presets for 90° and 45°.

Assembling and Attaching the Router to the Mounting Plate

Orient the mounting plate so that the two holes for the lead in pin are on the right. On the underside of the mounting plate are a number of concentric rings moulded into the material. Using these as guides place your router on the plate and mark the positions for the mounting bolt holes.



With most routers you can remove the face plate cover to use as a template for marking out. Leave this cover off the router, so that no cutting depth is lost. You may also be able to re-use the same screws to attached the router to the mounting plate.

Drill holes of the appropriate diameter in the mounting plate, turn the mounting plate over and countersink them to suit the screw head.

Bolt your router to the underside of the mounting plate. If you can, fit it in such a way that the speed control is easily accessible.



Note: In some cases it will be necessary to source new mounting screws. The size will vary according to the make and model of router being used.

Featherboards

For safe and accurate routing, three featherboards have been supplied and these should be used whenever possible.

Two featherboards should be fitted Vertically to the fence.

One featherboard in a horizontal plane attached to the table. There are two sets of holes to accommodate different sizes of work piece.

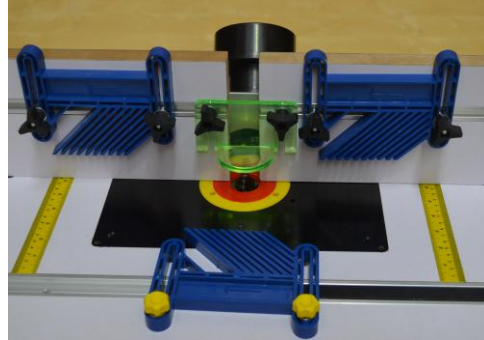

Optional Accessories

Collet Extension

A collet extension (CE12) is available to extend the plunge depth of your router. It can be used with 1/2" shank router bits and extends the collet by 65mm.



100mm Diameter Extraction

Our Connector (100/63RC) can be used to convert the extraction outlet for use with a 100mm diameter hose.



NVR switch

We strongly recommend the use of a secondary switch (W025) to start and stop the router without reaching under the table. It will be necessary to drill mounting holes in one leg of the table to mount the switch.



BASIC OPERATING INSTRUCTIONS

1) EDGING AND PROFILING

One of the most common operations undertaken using a router is Edging or Profiling, i.e. running a shaped cutter along the edge of the work piece. In many instances this is for decorative purposes but it can also be to make a joint or fitting such as a raised panel.

Using a router table for this type of work vastly reduces the setting up time required and does away with many awkward clamping devices. Router table users soon find that having both hands free to control the work piece, rather than holding a machine, makes the task far more comfortable and generally a lot safer.

SET THE CUTTER HEIGHT:- First fit a suitable cutter after making sure the router is unplugged. It is often easier to do this by lifting the mounting plate and router from the table. Draw a profile of the required cut onto the edge of the work piece and adjust the cutter height to match. Adjusting the cutter height is made much easier if a fine height adjuster is fitted to the router. With many models this now comes as standard, but on others it is available as an accessory produced by the router manufacturer. Having set the cutter height fit the router back into the table.

SET THE FENCE:- The next step is to set the fence in a position to give the desired width of cut. Use the profile drawn on the end of the work piece to set the fence and lock into position. There are two scales set into the table to assist in rapid fence setting. Make a note of the fence position if you are likely to run the same job again.

When using a cutter fitted with a guide bearing the fence should be set in line or just in front of the edge of the bearing so that the work piece runs on the face of the bearing. The distance between the two fence faces can be adjusted by undoing the plastic knobs at the rear and sliding the fence face along. The fence faces should be set so that the edges just clear the cutter. This provides the maximum amount of support to the work piece during the cut.

SET THE FEATHERBOARDS:- Adjust the Featherboards so that they provide a positive pressure against the fence or against the table. Set them somewhere between 2mm & 5mm less than the dimension of the work piece. This will hold the work piece securely up against the cutter and prevent 'kick-back' during the cut. When the featherboards are correctly set, the operator merely has to push the work piece across the table from right to left. It is still recommended to use a push stick for small work pieces.

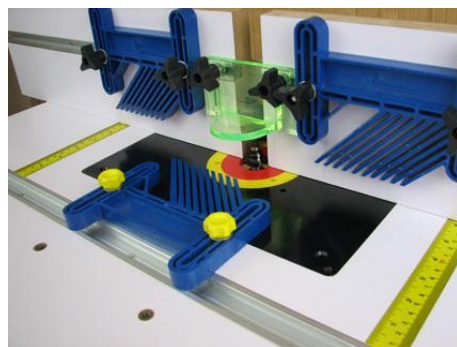

Please Note: Some work pieces may be too big to fit underneath the featherboards and they can simply be removed from the router table. The function of the featherboards is twofold; to hold the work piece securely against the cutter and to keep the hands well away from it. When using larger work pieces the increased weight will help to keep it against the cutter and the danger of hands being too near the cutter is greatly reduced.

SET THE CUTTER GUARD:- Adjust the perspex guard so that it just clears the top of either the cutter or the work piece. It will deflect any chips or dust which are thrown upwards. If possible, connect a dust collector or vacuum extractor to the dust outlet before commencing the cut.

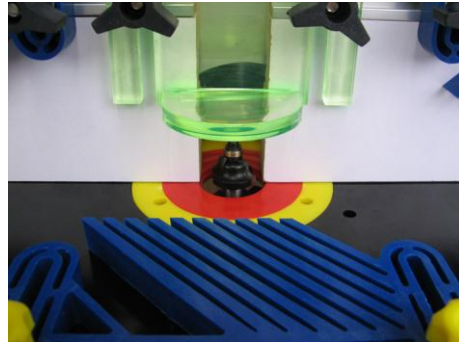

To test the settings you have made, make a cut with a scrap piece of wood before using the work piece. Mistakes cannot usually be rectified afterwards.

2) GROOVING

Grooving and Trenching operations are often carried out to form joints such as slot dovetails or to make fittings such as draw runner grooves.

SET THE FENCE:- The table is set up in the same manner except the fence will be set further back away from the cutter. The cutter guard can be removed and the 2 fence faces can be moved closer together so they are touching.

SET THE CUTTER HEIGHT:- For this kind of operation the work piece will be run directly over the top of the cutter. Set the cutter height carefully and ensure enough material is left at the bottom of the trench to avoid break out.

3) USING THE MITRE GUIDE

For some operations it is not possible to use the fence as a guide, for example cutting across the grain, trenching at an angle or cutting a tenon. To do these jobs the sliding mitre fence is used which runs in the aluminium T-slot across the front of the table.

SET THE BACK FENCE:- Undo the two plastic knobs and move it back to a position where it will not interfere with the cut.

SET THE ANGLE:- To change the angle of the mitre fence, undo the locking knob and read off the engraved scale on the casting. There are preset angles at 90 degrees and 45 degrees each way. Tighten the knob to lock the fence at the required angle.

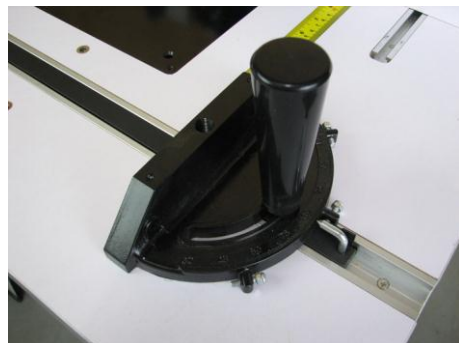

SACRIFICIAL FENCE:- The mitre fence can be enhanced by adding a longer wooden sacrificial fence to the front of the sliding fence. The sacrificial fence can run all the way up to the cutter and can be used to prevent breakout on the back edge of the work piece.

4) CUTTING CURVES

It is possible to put edge moulds on curved work pieces using the router table with the lead in pin fitted into the mounting plate to the right hand side of the cutter, and a bearing guided cutter. The bearing on top of the cutter does the job of the fence, restricting the cutting depth. The lead in pin is used as a steady to run the work piece against.

To make the cut, Hold the work piece against the lead in pin and gently press the work into the rotating cutter. Move the work piece around in an anticlockwise direction always feeding against the direction of the cutter.

If there is a curved shape you cut regularly, we recommend making a jig or template with handles and a safety rim around the edge to restrict the movement of the template.



5) REMOVING A COMPLETE EDGE

If the complete edge is to be removed you may need to step the outfeed fence to correctly support the work piece during the cut. The simplest way to achieve this is by undoing the two locking knobs on the back of the fence and inserting a shim of the desired thickness between the aluminium support and the fence face.

Parts List A: Table

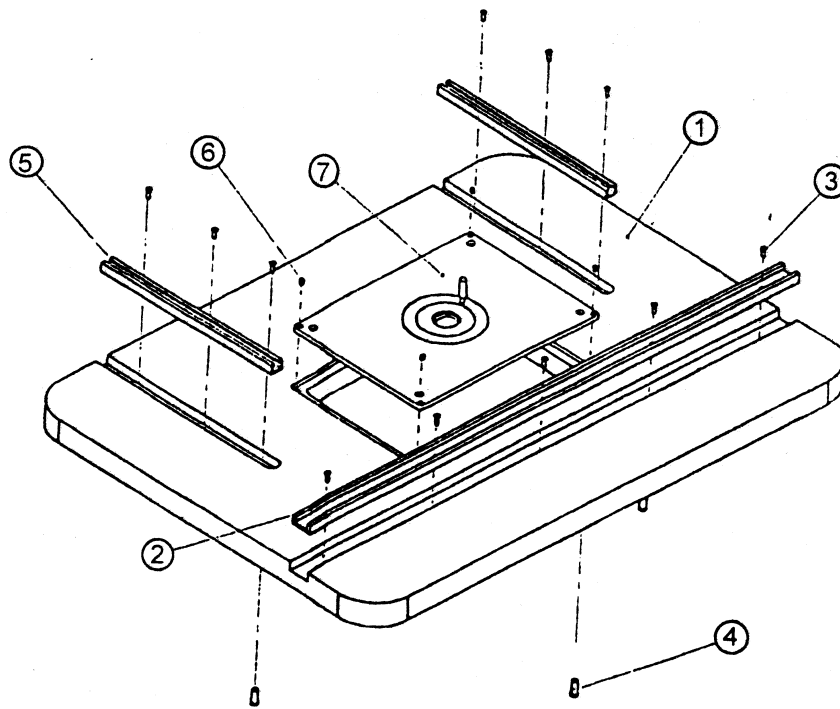

No.	Quantity	Description
A01	1	Table
A02	1	T-slot track for mitre guide
A03	4	Countersunk screw
A04	4	Magnet
A05	2	T-slot track for fence
A06	4	Metal Insert
A07	1	Lead in pin
A08	2	Scale for fence setting
A09	1	Yellow insert ring 67mm
A10	1	Red insert ring 32mm

Table Insert Plate

Pats list B: Fence

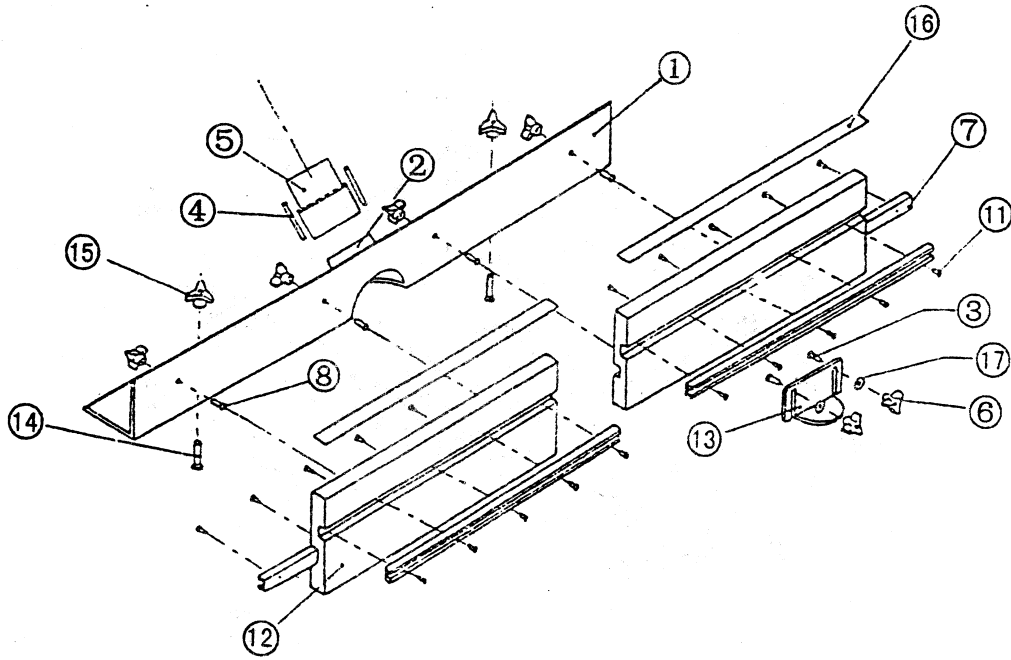

No.	Quantity	Description
B01	1	Aluminium fence support
B02	4	Black, castellated knobs
B03	2	Captive bolt
B04	2	Hex. head bolt
B05	1	Dust extraction port
B06	6	Black, tri-wing knob
B07	4	T-track
B08	4	Hex. head bolt
B11	20	Countersunk screw
B12	2	Fence
B13	1	Cutter guard
B14	6	Hex head bolt
B15	6	Black castellated knob
B17	2	Washer
B18	3	Featherboard
B19	2	Yellow plastic knob
B20	2	Washer

Parts list C: Stand

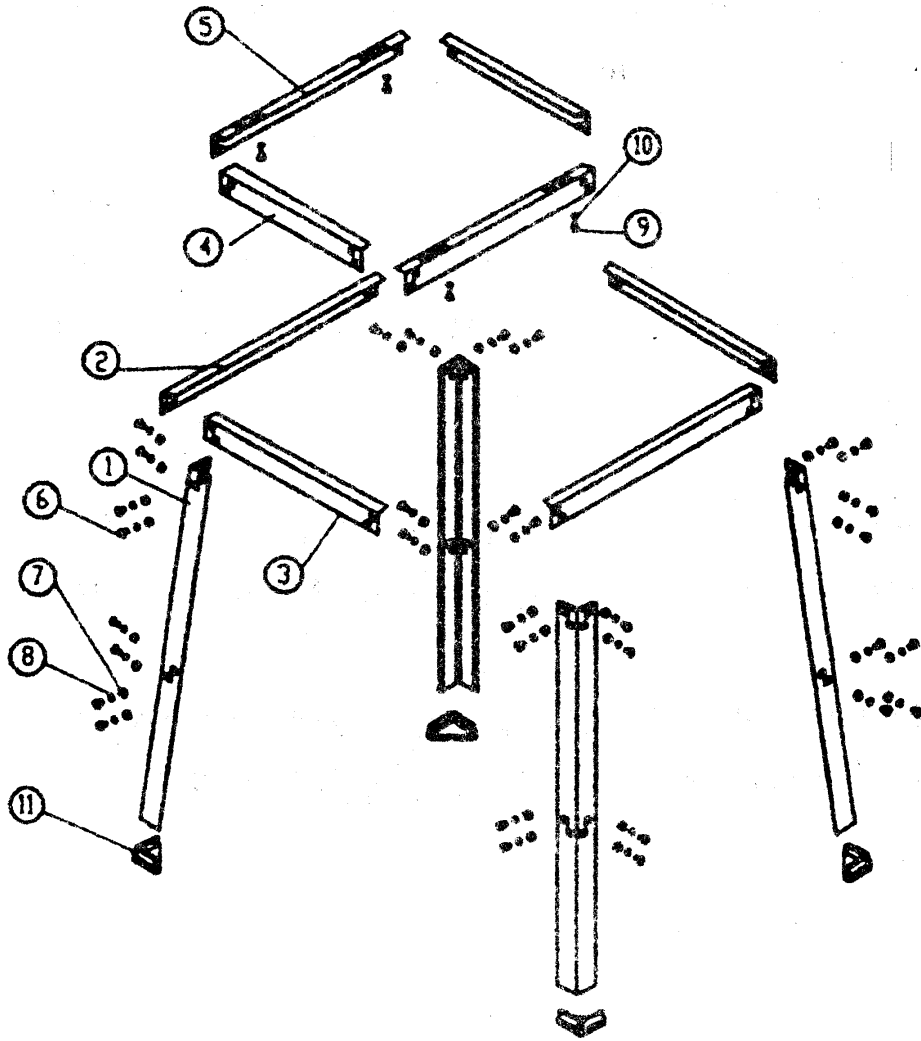

No.	Quantity	Description
C01	4	Leg, (grey)
C02	2	Lower front/rear brace (blue) 690mm
C03	2	Lower left/right brace (blue) 490mm
C04	2	Upper left/right brace (blue) 360mm
C05	2	Upper front/rear brace (blue) 560mm
C06	32	Coach bolt 8mm
C07	32	Nut 8mm
C08	32	Washer
C09	4	Hex headed bolt M6x16
C10	4	Washer
C11	4	Feet



Woodworking machinery at its best!

Charnwood, Cedar Court, Walker Road, Bardon, Leicestershire, LE67 1TU
Tel. 01530 516 926 Fax. 01530 516 929 email: sales@charnwood.net

www.charnwood.net